

Dairy Tech, Inc.  
*Service Manual: MilkWorks® Models*

# Operator Manual

## MilkWorks® Silver and Gold Models



# Dairy Tech, Inc.

## Service Manual: MilkWorks® Models

### Table of Contents

Introductions .....	3	Energy and Time Saving Tips.....	15
Did you know?.....	4	Trouble Shooting the MilkWorks® Gold ..	16
Product Warranty.....	4	No power to the control panel.....	16
Product Registration .....	4	Bath does not heat and the heater is not	
Receiving your Equipment .....	4	hot. ....	16
Important Safety Instructions .....	4	Bath does not get to temperature but the	
Installation: .....	5	Heater is hot and drawing current. ....	18
Location of the MilkWorks® .....	5	Data Transfer Failure Message .....	19
Optional Leg Kit .....	5	Error Messages.....	20
Connecting the Hoses for Water Cooling....	6	Temperature Display is erratic or	
Electrical Requirements.....	6	incorrect. ....	20
Heating Elements.....	7	Colostrum is separated or congealed .....	20
Grounding.....	7	Circulation Pump is not pumping .....	20
Operation of the Lid.....	8	Delay start does not come on	
Installation of the Basket .....	8	automatically.....	21
How to Use the MilkWorks® .....	9	Cycle starts automatically when toggle is	
Gold Model.....	9	switched on .....	21
Use of the Pasteurizer .....	10	Cooling solenoid valve will not stop	
Running the Cycles.....	10	running.....	21
Control Values.....	11	Troubleshooting the MilkWorks® Silver	
Understanding the Graph.....	11	Model .....	22
Silver Model .....	12	D10 Temperature Control .....	22
Starting the Silver Model.....	12	No Power to the Unit .....	22
Choose a Menu .....	12	No power to D10-Front.....	23
Filling and Emptying the Water Bath.....	12	No Power to D10-Rear.....	23
External Fuse Board .....	13	Water does not fill the unit when started	23
When Service is Required .....	13	Water enters the sink only briefly at	
Quality Control and System Monitoring ...	14	startup or will not replenish lost water...	24
Time & Temp for proper pasteurization:	14	The heater does not warm the bath for the	
Helpful hints for successful pasteurization:...	14	Ready State .....	24
Will I need to add anything to the milk after		No Heat during the Heating State .....	24
it has been pasteurized? .....	14	The unit is 3 phase and does not heat. ...	25
What if the milk becomes spoiled before I		Ready State bath temperature is too high	
pasteurize it? .....	14	.....	26
What is the optimal routine for handling		Timer does not operate properly. ....	26
colostrum?.....	14	Working with the MilkWorks® Gold control	27
Are there ways to preserve the colostrum if		SETUP WIZARD .....	27
refrigeration is not an option?.....	14	Instructions for Adding a New Profile.....	28
Will I harm immunoglobulins if I pasteurize		Control Configuration.....	29
colostrum?.....	15	How to Change from F° to C° .....	29
		Calibrating the Temperature .....	29

# Dairy Tech, Inc.

## *Service Manual: MilkWorks<sup>®</sup> Models*

To change a Profile .....	30
Accessories: .....	32
Wiring Schematic for MilkWorks Gold with DC Power Supply Used in Water Level Sensing Circuit.....	33
Wiring Schematic for MilkWorks Gold with 400VAC 3 Phase Supply .....	34
Wiring Schematic for MilkWorks Gold with AC Voltage Used in Water Level Sensing Circuit. ....	35
Wiring Schematic for MilkWorks Silver w/Switch Setting Delay Relay and 24Volt DC Power Supply. ....	36
Wiring Schematic for MilkWorks Silver with 400VAC 3 Phase Supply .....	37
Wiring Schematic for MilkWorks Silver w/Knob Adjustable Delay Relay and No Special Power Supply. ....	38
Replacement Parts List .....	39
Contact Dairy Tech, Inc.....	39

### Introductions

Thank you for purchasing a Dairy Tech, Inc. MilkWorks™ Series colostrum and milk management system. Your satisfaction with this product is very important to us. This guide will help you understand how your MilkWorks™ system operates, and how to get the most benefit from it for you and your dairy operation.

**THIS PASTEURIZER IS INTENDED TO BE USED IN THE MANNER DESCRIBED IN THIS USE AND CARE GUIDE. IT IS NOT APPROVED TO PASTEURIZE MILK OR OTHER GOODS FOR HUMAN CONSUMPTION.**

Dairy Tech, Inc. has provided this use and care guide to assist you in the assembly, installation, and maintenance of your MilkWorks™ Series colostrum and milk management system “Equipment”. Serious injury and even death to persons and livestock can occur from improper installation and use of this MilkWorks™ model. Serious property damage can result from improper installation and use of the Pasteurizer.

DAIRY TECH, INC. RECOMMENDS THAT  
INSTALLATION OF ANY ELECTRICAL, MECHANICAL,

GAS OR PLUMBING DEVICES REQUIRED FOR THE INSTALLATION, OPERATION AND MAINTENANCE OF THE DAIRY TECH EQUIPMENT BE DONE ONLY BY QUALIFIED INDIVIDUALS.

It is your responsibility or the responsibility of the electrician, plumber or other qualified installation expert to obtain all necessary permits and certifications required by your town, county, state or other jurisdiction before installation of the Equipment. It is your responsibility to read and understand the operational requirements of the equipment before using it and to observe all safety precautions. It is also your responsibility to see that your personnel are properly trained to operate and maintain the Equipment.

DAIRY TECH, INC. PROVIDES YOU WITH INSTRUCTIONS AND WARNINGS IN THIS USE AND CARE GUIDE, BUT WE ARE UNABLE TO COVER ALL POSSIBLE CONDITIONS AND SITUATIONS THAT MAY OCCUR IN YOUR DAIRY OPERATION. IT MUST BE UNDERSTOOD THAT COMMON SENSE, CAUTION AND CAREFULNESS ARE FACTORS WHICH CANNOT BE BUILT INTO THE EQUIPMENT. THESE FACTORS MUST BE SUPPLIED BY THE PERSON(S) INSTALLING, MAINTAINING OR OPERATING THE EQUIPMENT.

Under no circumstances is Dairy Tech, Inc., its directors, officers, shareholders or employees responsible for damage to property or injury to persons or livestock resulting from the improper installation or use of the Equipment. Installation by an unqualified individual and improper use and improper maintenance may also void any equipment warranty that Dairy Tech, Inc. offers.

This use and care guide is based on information and data considered to be accurate; however, no warranty is expressed or implied regarding the accuracy of the information or data herein or the results to be obtained from the use of this data or information.

**Please read this guide carefully and thoroughly before installing and operating the Equipment.**

We recommend professional installation by qualified plumbers and electricians familiar with such devices

If you believe the equipment is operating incorrectly, please refer to the trouble shooting guide included with these instructions before calling our service department. If you still have questions, contact your local representative or call 1-866-384-2697 and we will help you to address your needs.

# Dairy Tech, Inc.

## *Service Manual: MilkWorks<sup>®</sup> Models*



Dairy Tech, Inc. offers consultations with an independent Dairy Veterinarian at any time. If you have questions regarding calf health issues or other veterinary related topics, we would be glad to organize a conference call for you to discuss these.

**For your safety, the recommendations and information in the manual must be followed to minimize the risk of serious burns or electrocution, as well as to prevent property damage, personal injury or death.**

### Did you know?

**If you are burned by the heating coil, hot water, steam or hot milk:** Contact a physician or other medical personnel for expert advice, or go to an emergency treatment facility.

Do not feed heated milk to calves without first cooling it back down to no hotter than 110°F (43°C). Milk hotter than 110° can cause severe burns to the calves.

### Product Warranty

This product is warranted to be free of manufacturing defects. For up to 12 months from the date of purchase, all parts will be covered by a free replacement guarantee not including shipping or service. This warranty is intended for equipment in use under normal operating conditions and does not cover damages incurred by improper use or unforeseen acts of nature.

Determination of covered defects, damages or repairs is at the discretion of Dairy Tech, Inc. This warranty covers only the cost of replacement parts at Dairy Tech, Inc. current pricing. Service is not covered by this warranty. Parts replaced under warranty must be returned to Dairy Tech at 34824 CR 29, Greeley, CO 80631. Parts not returned will be charged to customer at retail pricing. Some replacement parts are included in your SPARE PARTS KIT for faster repair of common issues. These parts are not covered by the warranty because they are already provided to you at no charge.

### Product Registration

If this product was purchased directly from Dairy Tech in Windsor, CO, it has already been registered and no further action is required. If the product was purchased by a distributor or other representative, please call Dairy Tech, Inc. at 866-384-2697 within 10 days to register the product. Failure to do so

may result in a decreased or voided warranty period for your unit. When calling, please have the serial number which can be found on the back side of the control housing or back panel.

You may also register on-line at [www.dairytechinc.com](http://www.dairytechinc.com) where you can “Contact Us”, fill in your information and in the notes type the product model and serial number and the word “register”.

### Receiving your Equipment

Use care when unpacking your MilkWorks<sup>™</sup> Model. It will have arrived in one box or crate. Please make a note of any cautionary labels that are used on the carton suggesting orientation, where to cut with a knife, fragile, etc. Leg kits for the MilkWorks<sup>™</sup> are accessories that can be ordered at [www.dairytechinc.com](http://www.dairytechinc.com).

### Important Safety Instructions

#### Warning:

To reduce the risk of electric shock, burns, serious injury or death to persons when using the Equipment, follow these basic precautions:

1. Read all instructions before using the Equipment.
2. Make certain to install the Equipment on a sturdy table or countertop or purchase the accessory leg kit. When full of product the unit is quite heavy in excess of 250lbs.
3. Always disconnect the electrical power before attempting service. All power sources must be disconnected before any covers are removed for repair.
4. Do not allow children to operate or play around the Equipment. Close observation of children is necessary when the unit is used with children nearby.
5. Do not reach into the Equipment when the power is on and the pump is circulating. This can cause serious burns.
6. Hot Surfaces include the edge of the lid, plumbing fixtures, electrical fixtures, hoses, heater body, cabinet surfaces, draining water and the containers of milk or

# Dairy Tech, Inc.

## *Service Manual: MilkWorks<sup>®</sup> Models*

colostrum. Touching these surfaces during operation may result in severe burns.

7. This equipment is designed to operate in an ambient temperature range of 35°F (2°C) – 100°F (38°C), altitude up to 2000m, maximum relative humidity 80% for temperatures up to 31°C decreasing linearly to 50% RH at 40°C, for indoor use only.
8. Do not try to change the settings in the Equipment controller without consulting a technical expert at Dairy Tech, Inc.
9. Do not repair or replace any part of the Equipment, or attempt any servicing unless specifically recommended in the trouble-shooting portion of this manual. Any modifications made to the unit beyond these instructions will void all warranties.
10. Always clean the unit immediately after each use, according to the instructions in the “Cleaning of your Equipment” section of this manual. Build up of residue on the heating coils and inside of vessel will decrease heating and cooling efficiency, as well as harbor potentially harmful pathogens.
11. During the heating cycle, always make certain the Equipment lid is firmly seated on the sink top.
12. Do not force the lid into the closed position. It will close slowly as an intended feature. Forcing the lid to close faster than it is intended may permanently damage the slow closure feature.
13. The lid may be hot. Do not touch while in operation.
14. Use the Equipment only for its intended purpose. This is not an approved tool for milk intended for human consumption as this product has not been approved for such use.
15. Do not touch the tank of water, motor, hoses, lid, handle or metal fittings while the unit is hot and working.
16. Do not attempt to tilt the machine while it is full. It is extremely heavy and can cause severe injury to the operator and may cause failure of the support structures.
17. To prevent severe burns, always allow the milk or colostrum to cool completely before handling or feeding to calves.
18. The Equipment must be electrically grounded. DO NOT modify the plug that is provided with the Equipment; if it will not fit the outlet, have an electrician install a proper electrical outlet.
19. The Equipment must be installed on a level surface to evenly distribute weight to all the support structures.



### Installation:

#### Warning:

Install the unit according to these installation instructions. To reduce the risk of fire, electric shock, serious injury or death to persons, read the important safety instructions before operating this Equipment. Before using this unit for the first time, wash out the inside of the sink with hot soapy water and rinse clean.

- Nearby source of cold water
- A drain line that will not create any back pressure on the system
- Hot water source for cleaning purposes
- Enclosed area free of excessive dust
- Climate controlled enough to prevent freezing
- Avoid drafty areas when using the Gold Model
- Easy access for all day use by calf managers

Remove the unit from the packaging and place it in position to be used. There is also an optional leg kit available as described later in this document.

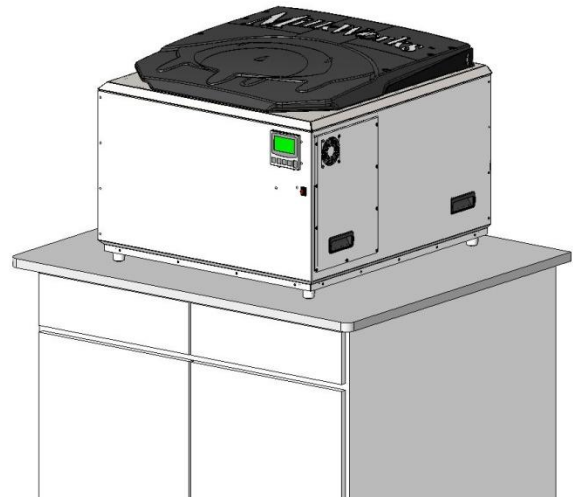

### Optional Leg Kit

See the end of this owner manual for assembly instructions pertaining to the optional leg kit.

# Dairy Tech, Inc.

## *Service Manual: MilkWorks® Models*

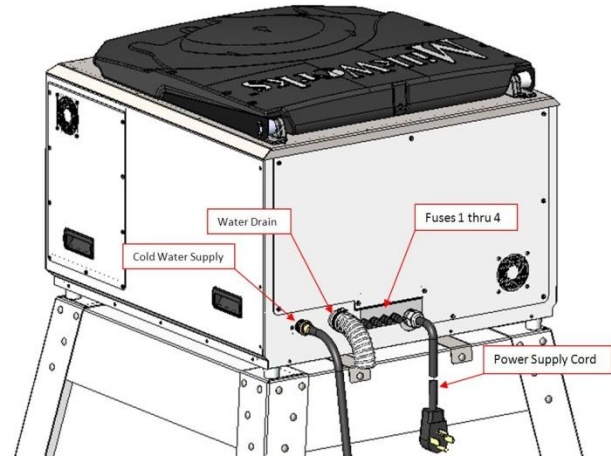
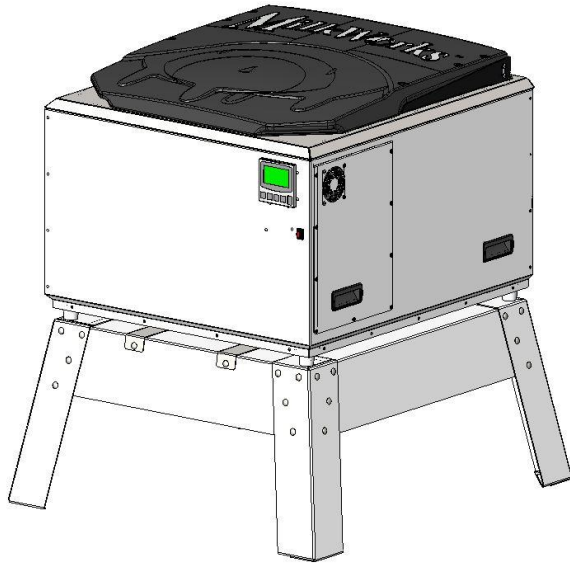

### Connecting the Hoses for Water Cooling

The MilkWorks® Models are both water cooled machines. A 6' black water supply hose is included with the machine. This hose with factory ends supplies all the cold water to cool the product when pasteurization is finished or when the unit is used to pre-chill colostrums bags. It can connect to any normal domestic pressure cold water source including a hose but it **MUST BE ON AT ALL TIMES DURING OPERATION**. Using the supplied hose, attach one end where indicated on the back of the unit, with the other end going to a regular hose bib supply. Pressure reduction is provided by the orifice of the solenoid valve.

Excess water leaves the unit by the interior drain line. This may occur when bags or bottles are placed into the machine and cause displaced water to overflow the drain. This is normal.

A corrugated drain hose is also included. This is a free flow zero-pressure hose that must fall to an open drain or into a bucket. If you wish to have waste water scavenged for other uses, place a sump pump into the bucket so that it can pump water to your secondary source as needed while not creating any back pressure.

It is important to keep water turned on anytime the MilkWorks is in operation to prevent damage to the heating elements and pump.



### Electrical Requirements

The standard electrical cord emerging from the back of the machine should be plugged directly into a 240vac grounded receptacle on a 30amp breaker for both the Gold and Silver Models. Take special note of the electrical label on the back of the machine to be sure. Failure to meet these requirements will void the warranty and could result in serious damage to the unit, bodily injury or death. The receptacle should be fitted with a water resistant cover for added protection. **ALL CONNECTIONS SHOULD BE PERFORMED BY AN ELECTRICIAN OR OTHER TRAINED PERSONNEL.**

- The receptacle should be sharing minimal usage with other equipment to avoid unexpected outages and tripping. If the power is lost, but returns within 1 hour, the cycle will resume automatically in most instances with the Gold Model. Silver Models will need to be restarted after power outages.
- MilkWorks® units at full power are rated at 19-22 amps. Do not install on circuit breakers greater than 30 amps.



# Dairy Tech, Inc.

## *Service Manual: MilkWorks<sup>®</sup> Models*

- Units designed for 3-Phase installations must be installed by a certified electrician according to local electrical ordinances. The main power consumption of the machine is a 4500watt heater. Wire gauge and current supply should be sized accordingly.
- DO NOT use an extension cord to operate the unit. Use only the cord provided.
- Check your electrical system to make certain it is properly grounded to avoid the possibility of electrical shock.

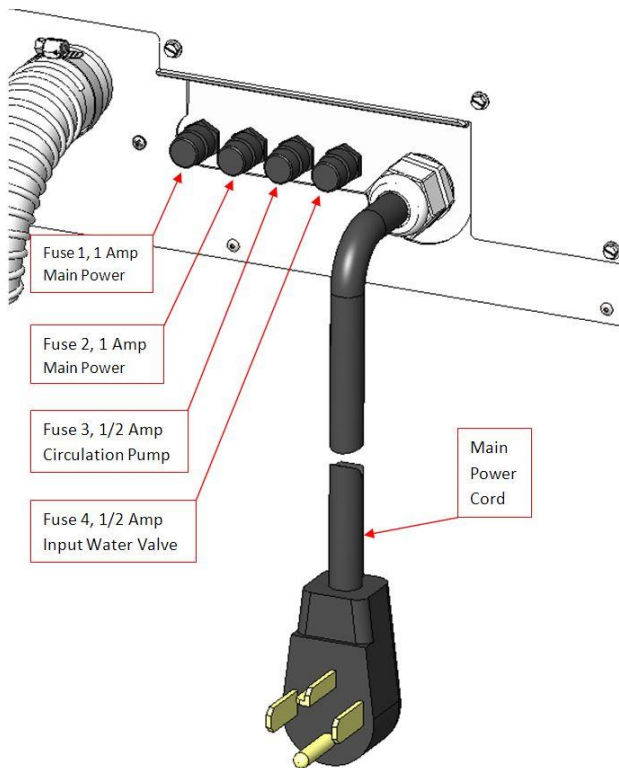

so that the element does not make contact with the two standoffs as it spirals inward from its mounting. Make certain all connections are tight before putting the MilkWorks back upright and filling with water.

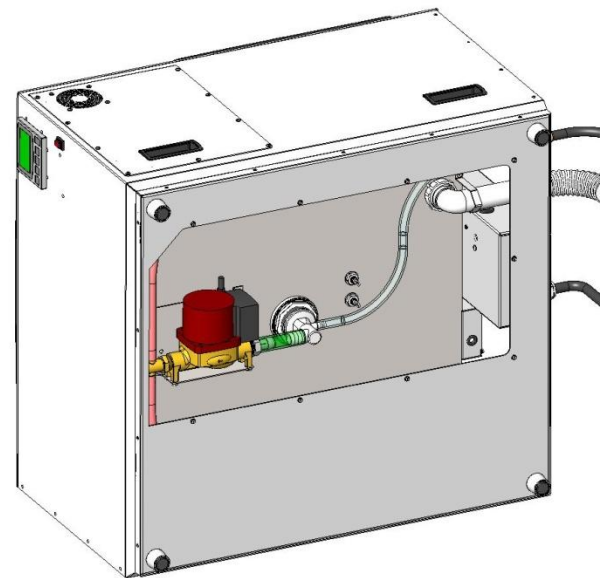
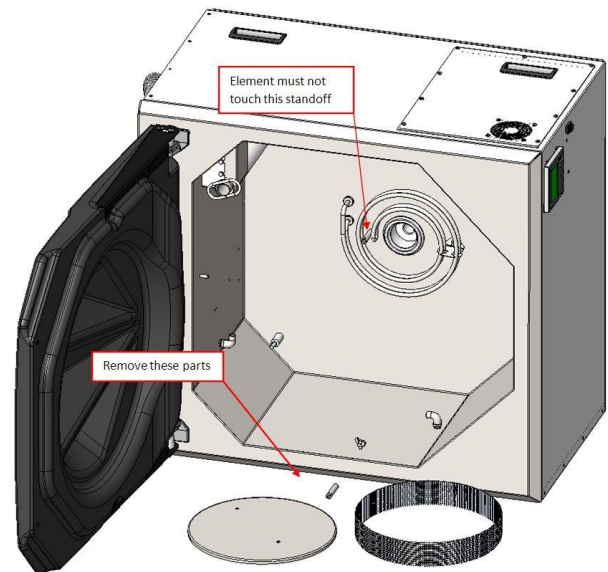

### Heating Elements

The heating element is easily replaced when necessary by first unplugging the machine and draining all water from the unit. Remove the basket from the sink. Remove the two screws holding the element filter and protector in place. Set the protector aside. Remove the standoff that is closest to the front of the machine. Roll the machine over onto its left side. Remove the bottom access cover. Remove the wire ends from the end terminals of the element. Remove the two nuts that hold the element to the sink bottom. Remove the element from the sink. Clean up any gasket residue before placing a new element into the sink. Reverse the disassembly procedure to install the new element. You may have to “shape” the element

### Grounding

The Pasteurizer is equipped with a cord having an equipment grounding conductor and a grounding plug. The plug must be

# Dairy Tech, Inc.

## *Service Manual: MilkWorks® Models*

inserted into an appropriate outlet that is installed and grounded in accordance with all local codes and ordinances. **DO NOT** modify the plug provided with the Pasteurizer; if it will not fit the receptacle, have a proper outlet or new plug end installed by a qualified electrician.



### Operation of the Lid

The lid is already attached and fully operational. It is designed with special resistance hinges that permit it to slowly lower itself onto the cabinet. All that is required is a simple start by hand and the lid can be released to close on its own. If force is used to push the lid down quickly, it will destroy the damper features of the lid and this benefit will be lost. This will not be repaired or replaced under warranty if the lid is forced to close even one time.

### Installation of the Basket

The MilkWorks® contains a stainless steel basket where bags and bottles of colostrum are placed for treatment. This feature should already be installed in your unit when you receive it. The basket is secured in position by 3 wing-nuts at 9, 12 and 3 o'clock positions. The lid of the basket can be raised by grasping the handle located at the 6 o'clock position and giving it a slight clockwise twist on the basket. This will release the lid from the latches and allow you to lift the lid.

The basket lid can be raised in order to insert Perfect Udder® bags of colostrum that are either fresh and ready for pasteurization, or they are cold/frozen and ready to be reheated for feeding. Once the bags are inserted, lower the lid and twist counter-clockwise to relock the lid. In some instances the basket may be optional for use with the Perfect Udder® bags as they can be placed into the unit without the basket.

If you use 3 quart bottles for feeding colostrum. They can also be placed into the basket by the same means. Make certain to use caps that are leak proof to keep the water bath clean.

Your MilkWorks® basket is designed to take full advantage of the Perfect Udder® colostrum management bags for rapid cooling, pasteurization and reheating of single serve colostrum feedings. The basket will also work with standard 2 quart feeding bottles. Follow the instructions below to install the bottle bails that will hold the bottles upright for reheating.

There are 10 bottle bails included with each basket.

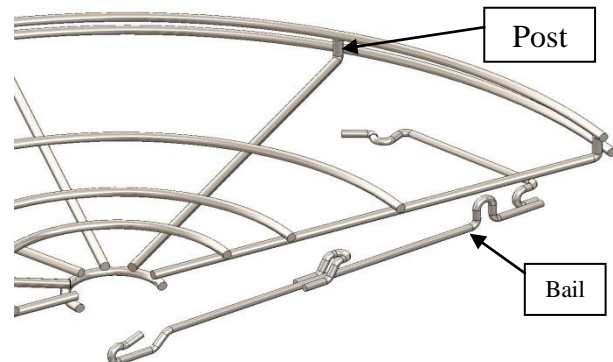

The basket lid is shown cut away in this view for better clarity. Start with the bail below the segment as shown here.

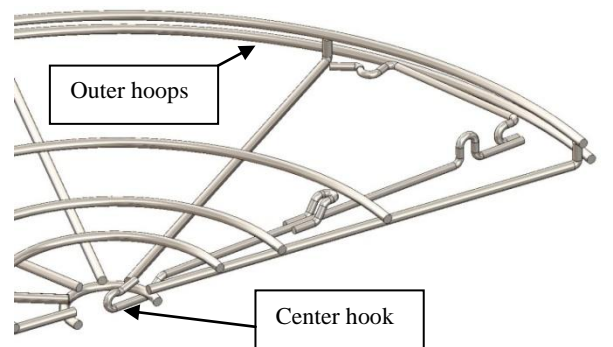

Raise the bail up as seen here, so that the forward part of the bail is lined up to enter the space that is between the outer hoops, and the center hook is set to snap onto the small hoop in the lid center.

Snap the bail into position making sure the center guide ends up on top of the hoop that will rest against the milk bottle. The center hook can be closed slightly with pliers if it will not stay in position.

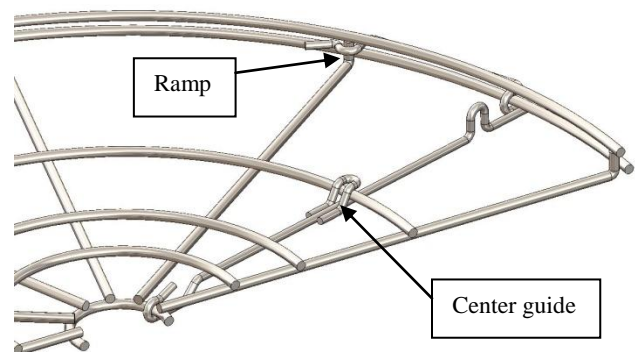



# Dairy Tech, Inc.

## *Service Manual: MilkWorks® Models*

Slide the bail over to the closed position and adjust the ramp wire if needed so that the bail is lined up to climb onto the post of the lid and will stay in the closed position after being placed there. The adjustment may be done by bending the wire slightly.



Move the bail to the open side to insert a 2Qt bottle.

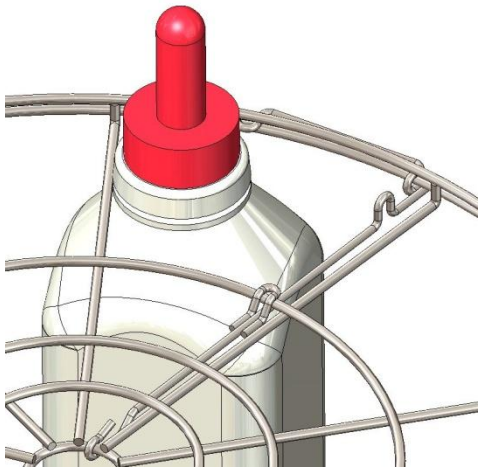

The bottle will pass through the opening of the basket when the bail is pushed aside as shown here.

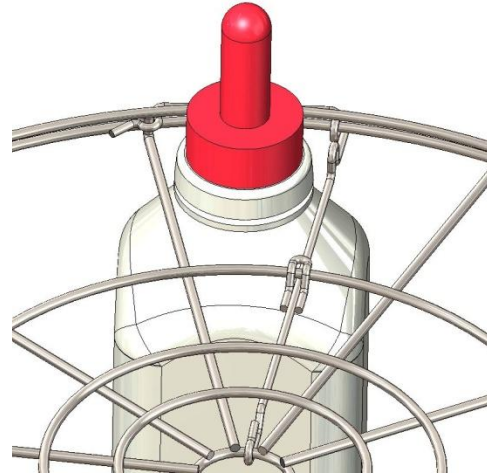

When the bottle is pushed all the way down, you can move the bail to the retaining position so that the bail will prevent the bottle from floating and escaping the hold of the basket.

If you wish to reheat frozen or refrigerated 3 quart plastic bottles, do not install the bails. Simply raise the lid and place the bottles on their sides under the lid. Make certain to use sealing caps on the bottles to prevent leakage. For a more convenient and biosecure method that also eliminates clean up, visit [www.PerfectUdder.com](http://www.PerfectUdder.com) for more information about these 3 or 4 quart colostrum management tools.

Never try to pasteurize colostrum or milk inside of plastic calf bottles. It is impossible to reach adequate temperatures inside the bottles and calf health will be seriously compromised.

### **How to Use the MilkWorks® Gold Model**

The Gold model was designed to be an all-purpose colostrum management tool. The main difference between the Gold and Silver models is that the Gold allows you to pasteurize colostrum using the Perfect Udder® bags. This unit comes equipped with the same control technology that is found on our Platinum Series of pasteurizers. With this control system, temperatures are able to be held within exacting tolerances to ensure that colostrum is properly heat treated without causing damage to the delicate immunoglobulin(Ig) proteins.

When the system is first plugged in and turned on, it will fill itself with water to protect the heating elements and pump.

# Dairy Tech, Inc.

## Service Manual: MilkWorks® Models

Once the float valve detects that sufficient water is available for safe operation, power will be sent to the controller ready for operation.

The water valve is designed to run for a brief period after the fill line is reached so that waves in the bath do not affect operation.

### Use of the Pasteurizer

The Gold model was developed to pre-chill, pasteurize, and reheat colostrum as it is stored in the Perfect Udder® colostrum management bags. Calf bottles filled with colostrum can also be chilled or heated in the MilkWorks® but it is not possible to pasteurize inside of these containers.

To begin, simply fill the Perfect Udder bags with raw colostrum and tighten the cap completely until the locking ring engages on the top of the bag spout. It is important to have a good seal to prevent spilling inside of the unit. As bags or bottles are placed into the bath, water that is displaced will overflow down the drain in the right rear corner.



### Running the Cycles

- Power the unit on by pressing the red push button switch; the display should run through some diagnostics, display

Dairy Tech Inc logo in red and then be ready for use once back to a green color.

- The Dairy Tech ProVu control system is designed with multiple menus to choose from. Custom menus are available if there are specific needs of a dairy. Use the return arrow key to the right (↩) to choose the operational mode screen with the options to Run, Abort, etc.
- Using the down arrow ↓, select Run Profile and then press the return arrow key ↩.
- Using the down arrow ↓, select a profile that you wish to run then press the return arrow key ↩.
- You will be asked if you are sure. Select YES and then press the return arrow ↩ key once again. The cycle should automatically start at this time and no further action is required until the cycle is finished.
- If you need to stop a cycle, turn off the toggle switch or disconnect the power in an emergency situation; otherwise, repeat the steps above and select ABORT the profile, then YES to confirm the action.

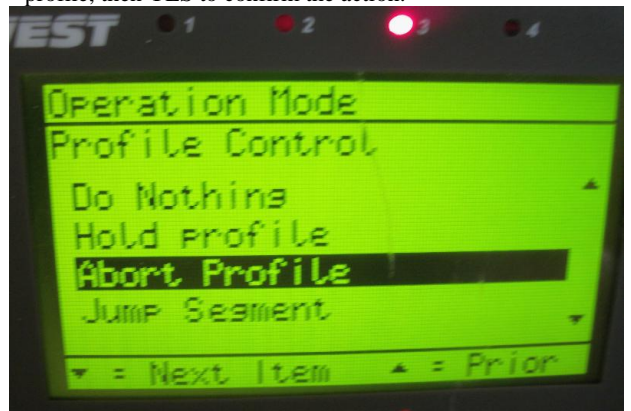

- The following menu options are available on the Milkworks Gold Model control:
  - Colostrum Normal Profile
  - Colostrum Heat Only
  - Colostrum Reheat Profile
  - Colostrum Cool Only
- Colostrum Normal is chosen for pasteurizing to 140F for 60 minutes with cool down to 90F.
- Colostrum Heat Only is used to pasteurize to 140 for 60 minutes without cooling.
- Colostrum Reheat is used to warm milk or colostrum back to feeding temperatures if it has been cooled after pasteurization.
- Colostrum Cool is to cool down milk or colostrum that was previously pasteurized, or to fill the tank with water on initial use.
- Milk 145 is used to pasteurize milk only batches at 145F for 30 minutes then cooling back to 90F

# Dairy Tech, Inc.

## Service Manual: MilkWorks® Models

➤Milk 161 is used to pasteurizer milk only to 161F for 30 seconds and then cooling back to 90F

Main Numbers are the temperatures displayed in F or C.

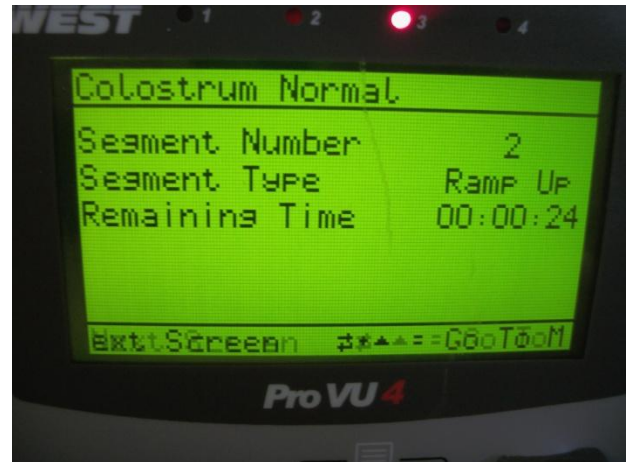
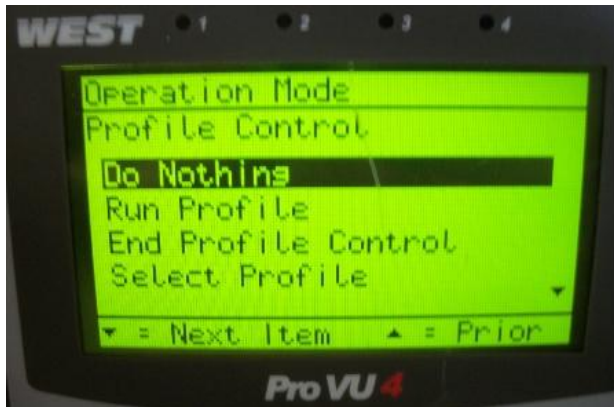

The Dairy Tech ProVu controller has several display screens that can be accessed during normal operation by using the left arrow ← and the return arrows ↵ to scroll. You will be able to see control values to view temperatures, see power functions of the machine as it proceeds through steps, and view a live graph to show temperatures recorded during the process. Data sets of the recorded temperatures can also be downloaded through the USB port and exported to an Excel spreadsheet for tracking.

### Understanding the Graph

Dashed Line – the setpoint curve for the process

Solid Line – process value temperature of the actual process

Bottom Hashes - sample time interval

Middle Number is the process Value ... the temperature of the milk and is the only important number on this graph

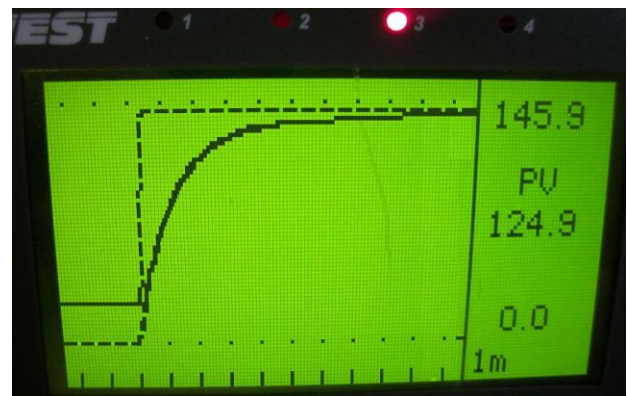

### Control Values

PV= Process Variable or temperature of the milk/colostrum

SP= Setpoint that the process is trending toward

%SPW/PPW= memory remaining or power of outputs

LED red lights in top indicate outputs for heating, cooling and stirring of the product.

The Dairy Tech ProVu controller has several display screens that can be accessed during normal operation by using the left arrow ← and the return arrows ↵ to scroll. You will be able to see control values to view temperatures, see power functions of the machine as it proceeds through steps, and view a live graph to show temperatures recorded during the process. Data sets of the recorded temperatures can also be downloaded through the USB port and exported to an Excel spreadsheet for tracking.



# Dairy Tech, Inc.

## *Service Manual: MilkWorks<sup>®</sup> Models*

### Silver Model

The Silver Model was designed for those dairies that already have colostrum pasteurization capabilities but now need a controlled method for properly preparing the colostrum for the newborn calf. The Silver model allows for rapid warming of colostrum that saves valuable time and also provides the immune function of colostrum to the calf in the quickest manner. All the while, the temperature controls of the MilkWorks prevent damage to the immunoglobulin (Ig) molecules that the calf needs for survival. We reheat colostrum the fastest, safest way possible based on solid research.

### Starting the Silver Model

When the unit is first turned on, it will automatically fill with water to the top. Once the unit is full, the heater will automatically turn on so that the water bath begins to prepare itself for use throughout the day. The Silver model works with a timer that enables the operator to select an amount of time based on what combination of products are to be prepared for consumption. To provide the best chance of getting the timing right, the Silver model preheats before it will allow operation. Preheating is indicated by a red light and once the operational temperature (90-100°F or 32-38°C) has been reached, the green light will turn on and permit the system to be engaged.

The system is designed to work with the Perfect Udder<sup>®</sup> bags or standard calf bottles as described earlier in this document.



### Choose a Menu

The Silver model also includes a menu of bag or bottle combinations that will allow you to determine the amount of time required for reheating of your colostrum. You will find that this process can occur 4X faster in the Perfect Udder<sup>®</sup> bags than it can in plastic bottles.

Find your combination of products on the chart and the corresponding time then turn the timer knob as shown below to the appropriate time. The circulation pump will engage to rapidly exchange heat evenly throughout the system. At no point will the water temperature exceed 140°F (60°C). This is to protect the Ig proteins. Always check the temperature of the colostrum prior to feeding calves. Temperatures greater than 120°F (49°C) will burn the esophagus of the calves and cause severe illness and/or death.

### Filling and Emptying the Water Bath

The MilkWorks does not need to be emptied completely between every use; however, it is recommended that the unit be drained every two days or any time that colostrum residue has spilled into the bath. To drain the system, raise the lid and pull the drain plug as shown in the view below. (This is also the tube where overflow water will exit the tank). Allow the unit to drain completely and then rinse with warm water followed by a hot water and detergent bath, finishing with a hot water rinse.

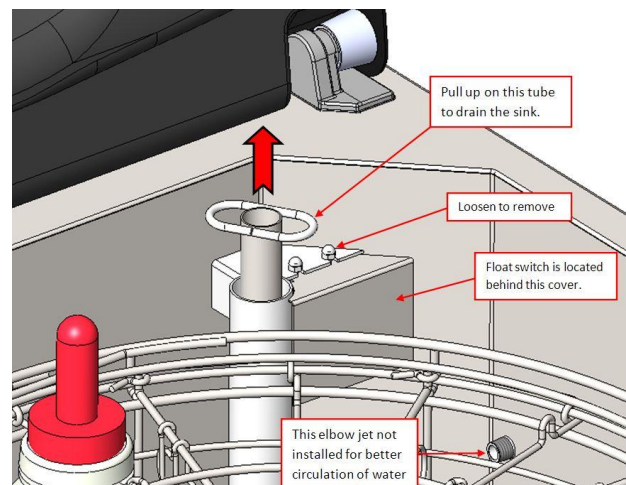

# Dairy Tech, Inc.

## *Service Manual: MilkWorks<sup>®</sup> Models*

### **CLEANING THE SYSTEM (be sure the equipment is powered OFF)**

- With the unit off and the pump stopped, raise the lid for full access. The bag basket may be removed by removing the 3 wing-nuts that hold it in place.
- Clean the following surfaces by rinsing with warm water to loosen fat and other debris, then clean with hot water and an appropriate disinfectant. Go over all the exposed surface areas with the included scrub pad and appropriate disinfectants to remove any residue on the following components:
  - Bag basket and attachments
  - Thermocouple well at bottom of bath
  - Underside of the pasteurizer lid
  - Bottom strainer and the corner drain area
  - accessory spigots, pitchers or hoses
- Stubborn residues may be cleaned with a scour sponge if necessary. Avoid the overuse of acids to prolong the life of the equipment. Follow manufacturers handling recommendations for all chemicals.

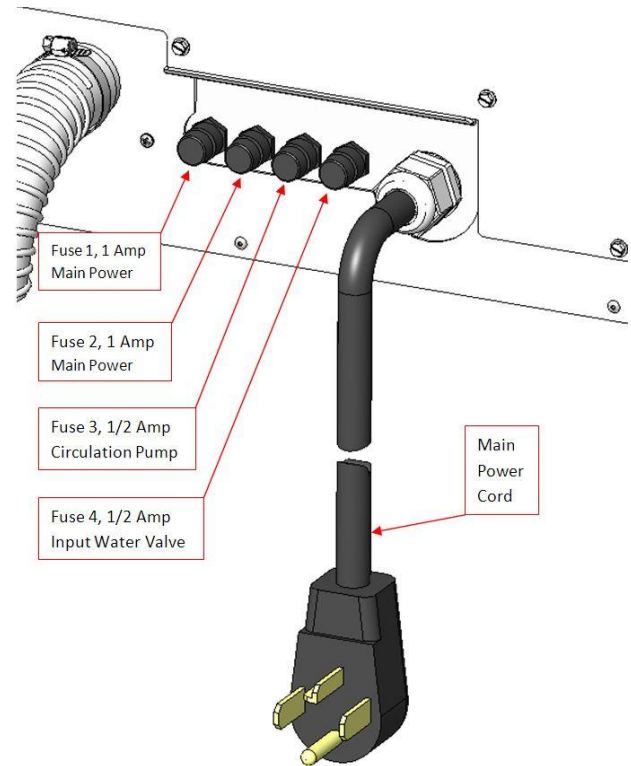

### **External Fuse Board**

The unit is equipped with 4 external fuses on the back of the unit. These fuses protect delicate electronics and also serve as a troubleshooting guide in cases of system malfunction. The layout of the fuses is described below as well as on the unit itself. Refer to Trouble Shooting for further information.

### **When Service is Required**

If you purchased the MilkWorks unit from an authorized dealer, contact them directly with inquiries or repair questions. For prompt service, work through the troubleshooting guide in this manual to give an accurate description of the problem.

Repair by an unauthorized service technician will void the warranty.

**[www.dairytechinc.com](http://www.dairytechinc.com)**

#### **Warning:**

There are parts of this machine and its contents that can cause severe burns if handled before the product is completely cooled. Always finish the cooling cycle before handling the products.





# Dairy Tech, Inc.

## *Service Manual: MilkWorks<sup>®</sup> Models*

### Quality Control and System Monitoring

The following recommendations should be carried out when the system is first installed and then on a monthly schedule to make certain that the pasteurization process is working adequately.

1. Follow all instructions for proper installation by thoroughly reading the manual.
2. Use quality colostrum in the machine. The process can be overwhelmed if there are too many bacteria to begin with.
3. Handle the milk cleanly after pasteurization to prevent recontamination.
4. Verify display temperatures periodically with a second thermometer to be sure that the displayed reading matches closely with a trusted calibrated source.

### Time & Temp for proper pasteurization:

**Milk 145°F(63°C)/30 minutes or 161°F(72°C)/30 seconds**  
**Colostrum 140°F (60°C)/ 60 minutes**

### Helpful hints for successful pasteurization:

\*Time pasteurization so that it happens as quickly as possible after harvest of the milk or colostrum. If pasteurization is not going to be started for more than a couple of hours, it will be important to first cool the milk or colostrum so that spoilage and pathogenic bacteria do not multiply in the product.

### Will I need to add anything to the milk after it has been pasteurized?

Not Usually. There are certain vitamins that are heat sensitive and may be decreased in concentration due to the pasteurization process but to our knowledge, no cases of deficiency or hypovitaminosis have been attributed to proper pasteurization. There may be circumstances due to regional or farm-specific conditions that would dictate supplementation of vitamins, minerals or even added fat/protein. Always check with your

local veterinarian if there are such suspicions and treat according to their instructions.

### What if the milk becomes spoiled before I pasteurize it?

This condition is fairly common and can happen at times even when the same successful routines have been followed. There are spoilage bacteria in milk and colostrum that release acid as their by-products. This is usually lactic acid but there are also others. The release of acid from these proliferating bacteria then drives down the pH of the milk making it more acidic. Once the product is pasteurized it is safe for the calves to drink, but this can lead to rancid odors and flavors that might decrease consumption by the calves. Digestibility might also be different which can lead to scours. In cases of severe drop in pH, the milk will separate completely with a very thick layer of “cheese” on top or thick like pudding throughout the product. This is not due to overheating, it is due to the fact that protein denaturation and separation is made worse by the added heat of the pasteurization process. Heat combined with spoiled milk of low pH is a bad recipe which is why we recommend that you always try to pasteurize as soon as possible after harvest.

### What is the optimal routine for handling colostrum?

We recommend that colostrum be pasteurized immediately after harvest and then either fed at once or cleanly transferred to a refrigerated holding vessel. The colostrum can then be reheated to body temperature prior to feeding.

### Are there ways to preserve the colostrum if refrigeration is not an option?

Yes. Potassium sorbate and other preservatives can be added to milk or colostrum that is already pasteurized and this will help to prevent the growth of any remaining bacteria in the product. It is important to note that K-sorbate will not kill existing bacteria but will prevent any new growth. Do not add it prior to pasteurization as it will cause a lower pH and the symptoms described above including thickened or separated product and bad flavors.

# Dairy Tech, Inc.

## *Service Manual: MilkWorks<sup>®</sup> Models*

### Will I harm immunoglobulins if I pasteurize colostrum?

NO. When done properly colostrum can be successfully pasteurized to eliminate the same pathogens that can be found in the milk. They are even more dangerous in colostrum since these bacteria and viruses can easily pass through the gut wall along with the large proteins that impart immunity to the calf. Colostrum can be safely pasteurized at 140°F (60°C) for 60 minutes to remove all pathogens without significant damage to immunoglobulins. Colostrum pasteurization should be as much a part of herd biosecurity as milk pasteurization.

### Energy and Time Saving Tips

- Pasteurize the colostrum as quickly as possible after collection to take advantage of the heat already in the colostrum to improve energy efficiency. This will also prevent the immediate heavy growth of bacteria in this fresh product.
- Avoid placing the unit in an area of high drafts to prevent convection heat losses while pasteurizing.
- Colostrum can be stored in the refrigerator for an extended period of time if it is handled cleanly once it has been pasteurized.
- Filling Perfect Udder™ Colostrum management bags allows for a disposable system that makes it easy to keep track of dates and colostrum quality.
- These bags also allow the product to be warmed more quickly when they are needed for the newborn and can then be fed without recontamination of the product. These can be ordered at [calfology.com](http://calfology.com), [perfectudder.com](http://perfectudder.com) or at [dairytechinc.com](http://dairytechinc.com).
- Always wear nitrile or latex gloves when handling the milk or colostrum to prevent the spread of pathogens from the skin surface.
- Even if you do not pasteurize your colostrum, quickly cooling the colostrum can prevent the rapid growth of harmful bacteria and give your calves an edge. The Perfect Udder® bags allow colostrum to cool 4X faster than it can in a plastic bottle.
- Never try to cool colostrum in 5 gallon buckets. Research has shown that this is one of the primary culprits in high bacterial counts on dairies.

# Dairy Tech, Inc.

## Service Manual: MilkWorks® Models

### Trouble Shooting the MilkWorks® Gold

**\*This guide is intended for use as a troubleshooting directive. All electrical tests and diagnostics should be performed only by those skilled in the electrical profession\***

**\*All electrical testing and repairs should be performed by an experienced professional or technician trained in the electrical trade\***

**\*Serious injury or death may result from improperly testing or handling this equipment\***

**\*This unit contains HIGH VOLTAGE electricity that can cause serious harm or death\***



#### No power to the control panel

- a. Check to be certain unit is plugged into 240vac outlet and that there is power at the outlet.
- b. Be certain that breakers in your electrical panel box are not tripped
  - i. If the breakers are being tripped, the system is likely being shorted to ground. Look for any blown fuses to indicate trouble areas and consult the fuse layout for more detail. Have the system

checked by a certified electrician before operating.

- c. Is the unit full of water? If the float switch is not elevated, it will not allow power to travel through the time delay relay and then onto the controls. Trouble shoot the float switch if the unit is full of water.
- d. Check the 1amp fuses (F1 and F2). Make sure there is line voltage to and through the fuses. If not, replace with appropriate fuse. **DO NOT REPLACE WITH OVERSIZED FUSES.**
- e. Voltage across the red and black wires of the switch should be at 240vac on the top leads and then across the bottom leads once the switch is depressed. No voltage when pressed indicates a bad switch that needs to be replaced.
- f. Make certain that the power connections between the front terminal block and the controller have not become loose. These are the wires at terminals 13 and 14 on the back of the control.
- g. The control itself could be malfunctioning or internally damaged. This is only rarely seen. Call for assistance.

#### Bath does not heat and the heater is not hot.

- a. Heat components: Control calls for heat by signaling the Solid State Relay (SSR) which then activates the contactor. When the contactor is pulled in it permits current to flow to the

# Dairy Tech, Inc.

## *Service Manual: MilkWorks<sup>®</sup> Models*

heating element but it also passes through a high limit thermostat to prevent runaway situations.

- b. Is there power getting to the contactor? Check voltage to the power input side of the contactor T1 and T3. There should be 240VAC across these two leads. If no power, check the breaker but power will also be off to the unit. Also check the wiring of the receptacle.

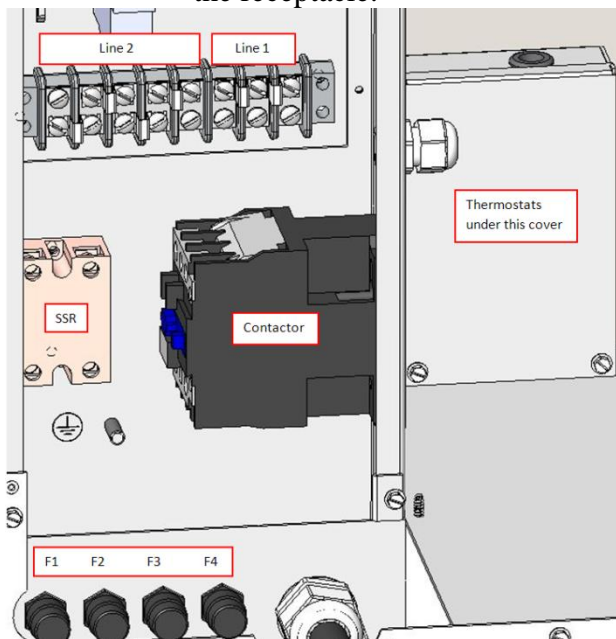

- c. Now check the power output sides of the contactor L1 and L3 once the unit is called to heat. If the SSR LED is lit but the contactor does not pull in and make a loud click, the contactor may be damaged.
- d. If there is power at the contactor output but not power to and through the Over Temperature Thermostat on the way to the

heater shown here, then try to reset the thermostat by pressing the Manual Reset Button. If the thermostat will not reset, replace it. If the thermostat does reset and this solves the problem, please inform Dairy Tech that this has occurred so that we are aware of it.

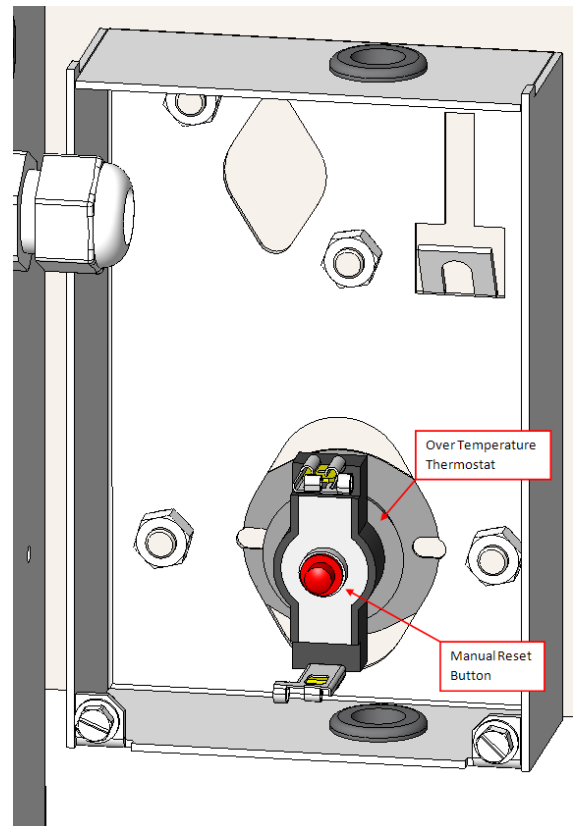

- e. If there is power through the thermostat but no current draw in the line, the heater is damaged and requires replacement.

# Dairy Tech, Inc.

## *Service Manual: MilkWorks<sup>®</sup> Models*

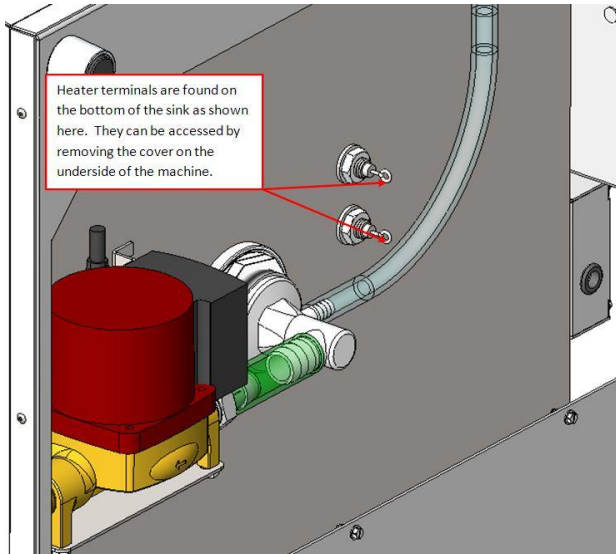

- f. Check the Solid State Relay (SSR)
  - i. Is there line voltage at A1 and A2 of the contactor when calling for heat? If not, check the SSR. There should be a D/C signal through the yellow and orange colored wires to the SSR and the LED on the SSR should be lit when activated. Line voltage is supplied to the SSR through the black wire at position 1. Once signaled by the D/C, there should be A/C line voltage out of the black wire position 2 to the contactor. If not, replace the SSR K1
  - ii. No D/C signal to the SSR through yellow and orange wires. Check to make sure the control is lighting up the small red LED for output 1 on the display when operating a normal heat

cycle. If output 1 is lit but no DC signal is found at terminal 12 and 21 from the control, then the control may be damaged.

- g. 240VAC is getting to the heating elements but still no heat, replace the heating element.

### **Bath does not get to temperature but the Heater is hot and drawing current.**

- a. This is a function of heat exchange. Check the amp draw and compare for a 4500watt heater with the local line voltage to determine if it is working at full capacity.
- b. Cold water is coming into the system. If there is a leak in the system, such as a leaking cold water solenoid valve, the heater cannot keep up and the bath will not heat properly. Repair the leak or replace the valve if water continues to flow out of the unit.

### **Water is leaking out the bottom of the Unit**

- a. Check the drain line to see if water is draining when it is not supposed to. May need to replace the seal in the bottom of the drain pipe. See next image.



# Dairy Tech, Inc.

## *Service Manual: MilkWorks<sup>®</sup> Models*

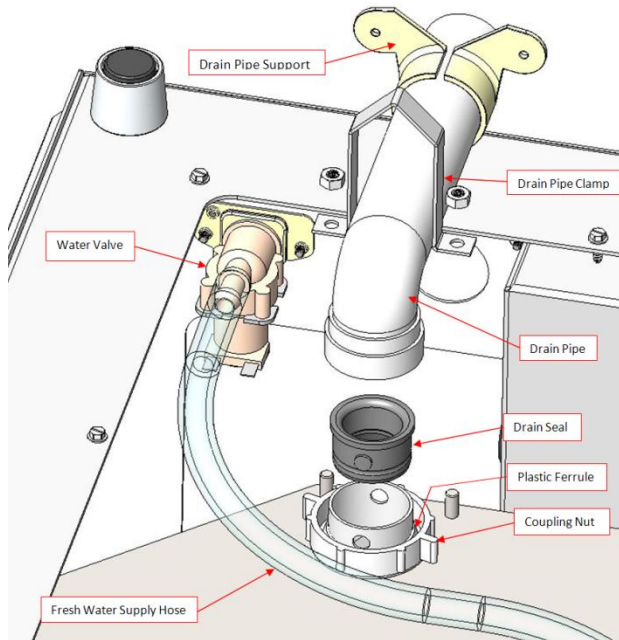

### **Bath will not cool**

- a. At the end of the heating and time-out cycle, the cooling solenoid valve should automatically open and flow cold water into the unit forcing out the hot water down the overflow drain.
  - i. Make certain the cold water supply to the unit is always on ... it is common to find that someone has shut the valve not knowing its importance.
  - ii. Make certain that the user did not initiate a "Heat Only" cycle after which the unit does not cool the bath automatically. Use the "Full pasteurization cycles" to make sure it goes through all steps.
- b. Check the cooling solenoid valve. The thermocouple temperature must be 100F, or above your cool setting in the control for the cycle to initiate.
  - i. During a cooling segment of the profile with the #2 LED on the control lit up, is there power to the solenoid valve? If the power is on and the machine has water but it will not flow, replace the valve.
  - ii. No power to the valve: Check the Circulation fuse (F3). Replace if necessary and check for power to the fuse from the control through terminal 22 blue wire. IF there is no line voltage power from the control at terminal 22 but the #2 LED is lit then the control may be damaged.
- c. Check the water supply to make sure screens and filters are free from debris and there are no kinks in the hoses.

### **Data Transfer Failure Message**

- a. IF the instrument cannot successfully write to the USB data stick, this message will appear when trying to download data points.
- b. Check that there is adequate disc space on the memory stick.
- c. This may also mean that the maximum number of profiles in the control has been exceeded.

# Dairy Tech, Inc.

## *Service Manual: MilkWorks<sup>®</sup> Models*

### **Error Messages**

- a. “Option Slot n Error” ... indicates a problem within the “n” module of the control itself and must be returned for servicing or be replaced.
- b. “OPEN” error indicates that there is a failed sensor (thermocouple wire), broken connection, or an internal input circuit has failed. Check the thermocouple wire and the connections into the back of the control at terminals #2(purple +) and #3(red -). Replace thermocouple.
- c. “ERROR” ... a fault has caused the equipment calibration to become corrupt. Call for recalibration options or return/replace the control.
- d. “HIGH” or “LOW” ... the process value or temperature of the product is beyond the limits set for the control to operate in. Be sure to operate in a room without severe conditions. Replace the control if error persists in normal conditions.

### **Temperature Display is erratic or incorrect.**

- a. Either the controller is corrupt or
- b. The thermocouples are polar sensitive and will yield erratic numbers or even move down in temp when the process is heating if they are wired in reverse. The unit may also flash an unusually high number and then immediately indicate that

the cycle has ended. Make certain that purple or white leads are positive (+) and red leads are negative (-) at all junctions.

- c. Is the unit housed in an extremely drafty location. Rapidly changing temperatures around the control can cause erratic temperature display.

### **Colostrum is separated or congealed**

- a. The most common cause for milk or colostrum to separate or congeal is acidification of the milk caused by two processes:
  - i. Fermentation of the milk by bacteria will cause the release of lactic acid and other acidic by-products resulting in a lower pH of the milk. This in turn allows it to separate. The heat of pasteurization will exacerbate this problem. To control this, cool the milk during holding stages or pasteurize the milk sooner after collection to prevent the start of fermentation.
- b. Acidic cleaners that find access to the colostrum can also cause a low pH and congealing of product.

### **Circulation Pump is not pumping**

- a. Check the fuse for the pump (F3)
- b. If the fuse is good, make certain that the wire to the pump has not

# Dairy Tech, Inc.

## *Service Manual: MilkWorks<sup>®</sup> Models*

- been damaged or pulled out of the terminal block.
- c. If there is power to the pump and it will not turn, replace the pump.
  - d. If there is no power to the pump and the fuse is good, check the control. There should be line voltage from terminal 24 to a neutral wire during heating or cooling. During heating, timing or cooling cycles, the red LED #2 should be on indicating power from the controller. If this light is not on, the control may be malfunctioning, replace the control.

### **Delay start does not come on automatically**

- a. Call for instructions to make certain the clock is set for the correct time of day.
- b. Make certain that the steps for using the delay start are being followed exactly. There must be a specific program sent to you for installation on the control if you wish for something other than those preset with your purchase.
- c. The control output could be damaged.

### **Cycle starts automatically when toggle is switched on**

- a. Your pasteurizer is equipped with a security feature that reminds it to come back on to its last unfinished cycle once power is restored after a power failure.

This will also occur if someone shuts the unit off prior to completion of its assigned cycles, and the unit will automatically restart when the toggle switch or power is restored. If a long time period has elapsed, the control will reset itself. If it does not it will restart when power is returned and must be reset by using the ABORT PROFILE command as listed on the control.

### **Cooling solenoid valve will not stop running**

- a. Check the power supply to the valve. IF there is power keeping it open during unwanted times, the control could be malfunctioning, especially if the cold output LED #3 is on at the wrong times. Replace the control.
- b. It is possible that some debris has held the solenoid open. Disconnect power and remove tubing from valve inside cabinet. Blow into the supply hose to eject any debris from the valve or force water backward through the valve.
- c. The valve may need to be replaced if it is powering properly but not closing when the solenoid closes

# Dairy Tech, Inc.

## *Service Manual: MilkWorks® Models*

### Troubleshooting the MilkWorks® Silver Model

#### D10 Temperature Control

The MilkWorks® Silver model contains 2 of the D10 Temperature controllers. These units are intended to control the temperature of the water bath during the Ready State as well as during the Heating State. In the rear of the unit behind the Back Access Panel the D10-Rear unit maintains the temperature of the water at 90-100°F (32-38°C). This allows the unit to be ready with a large heat sink for rapid warming of colostrum.

Seen from the front of the machine just above the timer knob, the D10-Front is located behind the red transparent plastic. In the rare event you need access to this control, gently push in on the sides of the red plastic part while lifting to free it from the holding tabs.



To access the control for setting adjustments, hold in the M button for 5 seconds to display

the function screens. Press the S button to see the value for that function and then the UP and DOWN arrows to make adjustments to that function. To save a setting, press the S button again to return to the Function display.

The following is a list of the normal parameter settings for the D10 control

- F11 set point temperature  
100°F (38°C) in the D10-Rear  
140°F (60°C) in the D10-Front
- F12 temperature difference  
10°F (12°C) in the D10-Rear  
1° in the D10-Front
- F13 max temperature = 180°F (82°C)
- F14 min temperature = 35°F (2°C)
- F19 used to calibrate temperatures
- F29 temp mode = HEAT
- F50 Ext alarm mode = 0
- F80 password = OFF
- F81 Temperature Units = F or C

To exit the control, simply press the M button.

#### Possible Error messages

- A21 flashing “SHr” means temp sensor is shorted out and must be replaced.
- A21 flashing “OPE” means the temp sensor is either; broken, disconnected or damaged and may need replaced.

#### No Power to the Unit

1. Make sure that the unit is plugged into the receptacle and check the breaker for the power supply
2. Check fuses F1 and F2, replace if necessary
3. Is there power to the switch at the front of the unit from black to red? If yes but

# Dairy Tech, Inc.

## Service Manual: MilkWorks<sup>®</sup> Models

no light on the switch then replace the switch.

### No power to D10-Front

1. Check the leads coming from pin 11 and 12 on the control where they connect at the front terminal strip. If there is power at the terminal strip but nothing on the display, remove the wires from the D10 control at pins 11 and 12 to make certain the wire has not failed. If the wires are delivering the voltage, replace the D10 control.
2. The D10-Front control relies on a supply from K3 which is only active if the float switch is "UP", the timer has been wound and the green light indicates Ready State has been reached. If the D10 has power but will not signal the contactor, troubleshoot these other components.

### No Power to D10-Rear

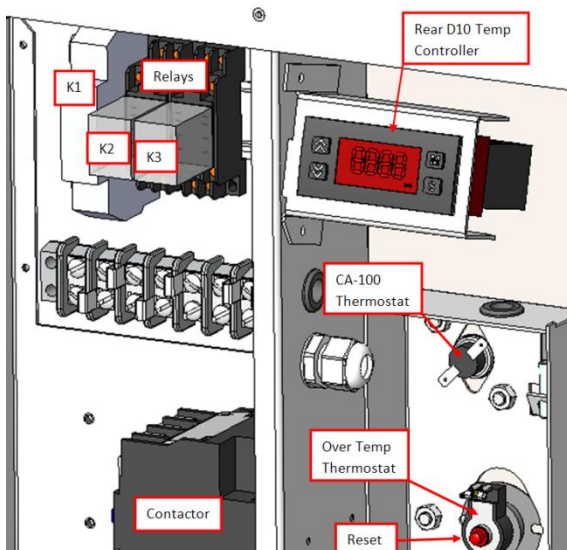

1. Check the leads coming from pin 11 and 12 on the control where they connect at the rear terminal strip. Pins 11 & 12 are the ones closest to the large electrical connections box. If there is power at the terminal strip but nothing on the display, verify the wires and replace the D10 control.
2. If the D10-Rear has power but will not signal the contactor, check for voltage getting through thermostat CA-100 and replace if necessary.

### Water does not fill the unit when started

1. Make sure that the water supply is connected at the valve in the rear and that the water is turned on.
2. Check the fuse F4 and replace if necessary
3. The water valve can only turn on if the float switch is not sending line voltage to the delay start relay K1 at the A1 terminal.
  - a. Check for voltage between A1 and A2 terminals on K1. If line voltage is present, check to make sure the float switch is not stuck in the up position. Replace float switch if necessary.
  - b. If the fuse F4 is good, check for line voltage between pin 16 on K1 and the red Line 2 wire at the valve. If no voltage then replace the Delay Relay K1.
  - c. If there is voltage between pin 12 on K1 and red Line 2 on the valve but no water flow, replace the valve.



# Dairy Tech, Inc.

## *Service Manual: MilkWorks<sup>®</sup> Models*

### **Water enters the sink only briefly at startup or will not replenish lost water**

1. Check the voltage across A1 and A2 on delay start relay K1. If there is 24VDC there, and the float on the float switch is in the bottom position, replace the float switch.
2. If the float is in the top position and there is not 24VDC across A1 and A2, replace the 24VDC power supply.
3. If when the water level is high enough to raise the float to the top position, but there is no water added to the sink by the valve when you depress the float downward, check to see if you read the same AC line voltage value at both pins 15 & 16 of relay K1. If they are the same, replace the water valve. If they are different, replace the float switch.

### **The heater does not warm the bath for the Ready State**

1. During the Ready State the heater responds to a signal from D10-Rear. Check for voltage at A1 and A2 on the contactor. If there is voltage here but the contactor does not engage, replace the contactor.
2. If there is no voltage at A1/A2 on contactor then troubleshoot the D10-Rear control
3. If the temperature of the bath is above the set point for the D10-Rear control, it will not signal the contactor to engage heaters.
4. If there is power at the contactor output but not power to and through the Over Temperature Thermostat on the way to

the heater shown here, then try to reset the thermostat by pressing the Manual Reset Button. If the thermostat will not reset, replace it. If the thermostat does reset and this solves the problem, please inform Dairy Tech that this has occurred so that we are aware of it.

5. Check for line voltage between Contactor L3 and both sides of the manual reset thermostat. If voltage to both sides but no current to the heater, then replace the heating element.

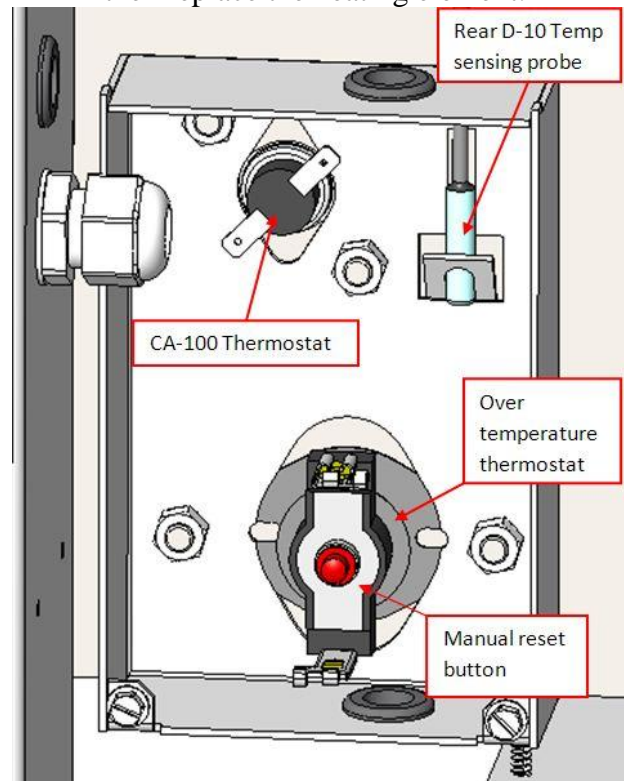

### **No Heat during the Heating State**

1. During the heating state, the heater is controlled by the contactor which receives signals from the D10-Front control. Note in the schematic that the D10-Front can only work properly if the

# Dairy Tech, Inc.

## *Service Manual: MilkWorks<sup>®</sup> Models*

float switch is in the up position, the unit has reached the Ready State as indicated by the Green light, and the timer is wound. Troubleshoot these areas if the D10-Front control does not seem to signal the contactor A2 pin.

2. If there is no voltage at A1/A2 on contactor then troubleshoot the D10-Front control
3. If the temperature of the bath is above the set point for the D10-Front control, it will not signal the contactor to engage heaters.
4. Check for line voltage between Contactor L3 and both sides of the over temperature thermostat. If voltage only to one side then try to reset the thermostat by pushing the center button. If it will not reset, replace the thermostat. If the thermostat does reset and this solves the problem, please inform Dairy Tech that this has occurred so that we are aware of it.
5. Check for line voltage between Contactor L3 and both sides of the over temperature thermostat. If voltage to both sides but no current to the heater, then replace the heating element.

### **The unit is 3 phase and does not heat.**

Before attempting any of the suggestions given below, you are strongly urged to perform the checks for all heat related issues, which are prior to this step in this manual.

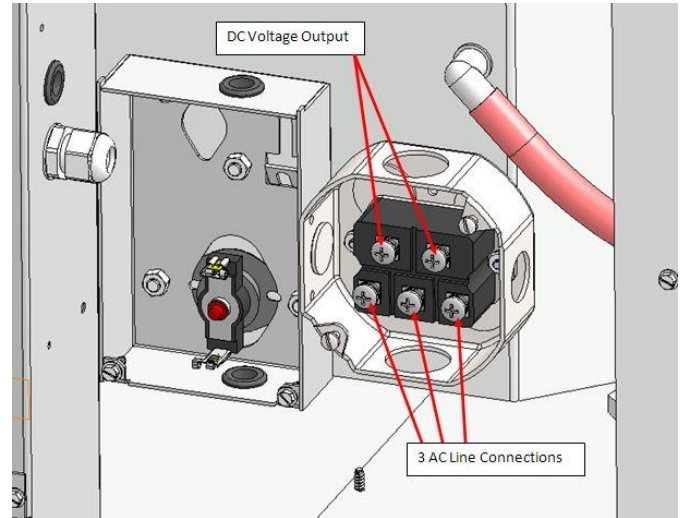

1. In the rear, remove the blue cover from electrical box. **INSIDE THE COVER OF THIS BOX THERE ARE LETHAL VOLTAGES PRESENT. EXTREME CARE AND BEST PRACTICES MUST BE UTILIZED WHILE PERFORMING THESE CHECKS.** Check to see if each phase is arriving at the rectifier mounted there. This will only be the case when the unit is calling for heat. Be sure the contactor is pulled in when you are making these measurements. You should be able to measure 230 volts at any of the 3 phase inputs when your other meter lead is touching any other of the 3 phases.
2. If you are not seeing 230 volts at ALL of the input lines, check to make certain all lines are arriving at the contactor from the mains, and are passing through the contactor. If the mains are arriving at the contactor but are not ALL passing

# Dairy Tech, Inc.

## *Service Manual: MilkWorks<sup>®</sup> Models*

through it, AND the contactor is pulled in, change the contactor.

3. If you are seeing 230 volts at all of the input lines, you should see about 325VDC on your meter when you check across the two output terminals of the rectifier. (Watch the polarity if your meter is not auto ranging.) If you do not see approximately this voltage on the DC scale of your meter, the rectifier has failed.

### **Ready State bath temperature is too high**

The D10-Rear control is responsible for the bath temperature in the Ready State. It begins to control the water temperature as soon as the water is finished flowing into the sink. There is interaction with the Auto-Reset Thermostat CA-100 even though the D10-Rear is not controlled by it. If the temperature of the water bath is above the set point on D10-Rear by more than a few degrees, the CA-100 thermostat may be out of calibration range and should be replaced.

### **Timer does not operate properly.**

1. The timer should make the clock tick audibly when wound clockwise. If not, replace the timer.



2. The timer can only function if the Ready State is reached. This is when the CA-100 thermostat passes Line 2 voltage to Relay K2 pin 14, the Green light is on, and the float is in the “UP” position. Check these conditions. Replace K2 cube relay if Line 1 voltage is not available to the timer but these other conditions are met.

for parts list and ordering visit  
[www.dairytechinc.com](http://www.dairytechinc.com)

# Dairy Tech, Inc.

## *Service Manual: MilkWorks<sup>®</sup> Models*

### **Working with the MilkWorks<sup>®</sup> Gold control**

These are the parameters to be set for the Dairy Tech MilkWorks<sup>®</sup> Gold controls.

#### **SETUP WIZARD**

Enter the menu by first powering the unit and wait for the self check to be completed.

While holding the RETURN button, press the UP arrow to enter the main menu.

Scroll to select the SETUP WIZARD using the UP and DOWN buttons.

Enter the security password which is 10.

Thermocouple:	Type E
Engineering Units:	F or C depending on country <b>***hint***</b> if you select C, the profiles must individually be changed to Celsius as well. This is not automatic for the profiles <b>***</b>
Decimal Point Position:	123.4
Scale Input Range Lo Limit:	0 (make sure it is 0 when in Celsius)
Scale Input Range Upper Limit:	300 (make sure it is set to 100 in Celsius)
Control Type:	Single
Primary Control Action:	Reverse
Select Automatic or Manual Control:	Automatic
Output 1:	Primary Power
Output 2A:	Event & Alarm
OP2A Usage:	Event 1, Direct Acting
Output 2B:	Event & Alarm
OP2B Usage:	Event 2, Direct Acting
Output 3:	Event & Alarm
OP3 Usage:	Event 3, Direct Acting
Setpoint Selection:	Local Setpoint 1 Only
Local Setpoint 1 Value:	7.0 F
Alarm 1: Unused	
Alarm 2: Unused	
Alarm 3: Unused	
Alarm 4: Unused	
Alarm 5: Unused	
Date Type:	mm/dd/yyyy
Date enter	
Day enter	
Time enter	
Run Pre-Tune: NO	

# Dairy Tech, Inc.

## *Service Manual: MilkWorks<sup>®</sup> Models*

### Instructions for Adding a New Profile

A new profile may be desired for special circumstances on a dairy that calls for variations in temperature, time of cycles, time of day to start a cycle automatically, or complex profiles that allow multiple functions.

New Profiles must be written according to the controller code and is normally done by Dairy Tech trained personnel and the new profile is sent to the dairy or dealer via email. This file can then be loaded onto a memory stick and inserted into the USB port located under the grey rubber cap on the front of the control.

Step 1. You must start with a memory stick that has been initialized by the West control on your Dairy Tech MilkWorks<sup>®</sup> pasteurizer. To do this, simply turn on the pasteurizer so that the control lights up. Insert your memory stick into the front of the machine by gently prying off the rubber protective cap that covers the USB port on the front lower right of the control.

Insert the memory stick and the control will display the message “initializing memory stick ... do not remove”. The unlock code is 10. When it is finished it will ask you to press the return button. Now the controller has configured your memory stick with the appropriate files so that it can handle data that is usable by the control. Remove the memory stick, hold the enter button and press the up arrow twice to return to the main screen then power down the control.

Step 2. Insert your memory stick into your computer so that you can open the email with your custom file on it and save to the memory

stick. You may have to go into the USB drive for the memory stick and make certain that the new profile file is saved into the correct place. When you initialized the memory stick it created a large file called DEVICE. Inside this are 3 subfiles: RECORDER, CONFIG and PROFILE. You will want to make sure that you save your new custom profile into the PROFILE folder.

Step 3. Now you can insert the memory stick into a West control on a Dairy Tech MilkWorks<sup>®</sup> pasteurizer. It will once again initialize. The unlock code is 10. Scroll down to READ PROFILE FILE ... press ENTER  
Select the new file from the list or it may be the only one ... press ENTER  
It will ask CONFIRM READ? Scroll to YES and press ENTER  
Wait while the control reads the file and shows TRANSFER SUCCESSFUL... press ENTER  
Remove the memory stick and replace the rubber cap over the USB slot.  
Hold the ENTER button while pressing the UP arrow twice to return to the front screens

Step 4. Use the pasteurizer normally and choose the new profile from the list of options when running a profile.  
This action of inserting the memory device will prompt the user to press a key to initialize the memory stick. Once this step is completed, follow these steps to add the new profile to the list of existing profiles.



# Dairy Tech, Inc.

## Service Manual: MilkWorks<sup>®</sup> Models

### Control Configuration

In this menu, we set the configurations for the control which help determine the PID process for temperature control.

From the operational mode when the machine is first turned on hold the RETURN button and press the UP ARROW one time. Then use the DOWN ARROW to scroll to 'configuration menu'. Press the RETURN button and enter the unlock code which is 10 by scrolling with the UP ARROW, then push RETURN.

Scroll down and choose 'control configuration' from the menu and press RETURN.

You are now in the menu and can move back and forth using the RETURN or BACK ARROW keys, and the UP and DOWN keys to make adjustments. Here are the settings

Control enable/disable	control enabled
Select auto/man ctrl	auto ctrl only
Control type	single
Primary control action	Reverse
Control status (Do nothing ... it will show ambient and setpt)	
Primary Power	0.0%
Primary Proportional Band	0.5%
Integral Time	15:00
Derivative Time	3:55
Manual Reset Bias	25%
Primary Cycle Time	20.0 sec
Primary Power lower limit	0.0%
Primary Power Upper Limit	100.0%
Sensor Break	OFF
Setpoint Selection Method	Local
Setpt 1 Only	
Setpoint Lower Limit (also 0° when in Celsius)	0°F

Setpoint Upper Limit (set at 100° when in Celsius)	300°F
Ramp in Operator Mode	NO
Setpoint Ramp Rate	OFF
Local Setpoint 1 Value	7

### How to Change from F° to C°

From the operational mode when the machine is first turned on hold the RETURN button and press the UP ARROW one time. Then use the DOWN ARROW to scroll to SETUP WIZARD and follow the instructions listed above to change the engineering units from F to C ...  
WARNING: switching from F to C should automatically adjust profiles from F to C. A video demonstrating this procedure is available at [www.dairytechinc.com/support](http://www.dairytechinc.com/support)

### Calibrating the Temperature

If you find that one or more secondary thermometers disagree with the control display, you can adjust the temperature settings in the control to make up for the difference.

From the operational mode when the machine is first turned on hold the RETURN button and press the UP ARROW one time. Then use the DOWN ARROW to scroll to 'configuration menu'. Press the RETURN button and enter the unlock code which is 10 by scrolling with the UP ARROW, the RETURN.

Scroll down and choose 'Input configuration' from the menu and press RETURN.

You are now in the menu and can move back and forth using the RETURN or BACK

# Dairy Tech, Inc.

## Service Manual: MilkWorks<sup>®</sup> Models

ARROW keys, and the UP and DOWN keys to make adjustments. Here are the settings:

Input Type	E thermocouple
Engineering Units (your preference)	F (C if that is your preference)
Decimal Point Position	123.4
Scale Input Range Lower	0°F (when in Celsius, check to make sure this is 0° also)
Scale Input Range Upper	300°F (when in Celsius, check to make sure this is 100°)
Cold Junction Compensation	Enabled
Process Variable Offset	OFF (this is the value you would decrease or increase to adjust a calibration issue with the temperature ... OFF is Zero)
Input Filter Time	2.0 s
Calibration Reminder	Disabled

TO EXIT THE MENU, HOLD THE RETURN KEY AND PRESS UP ARROW REPEATEDLY UNTIL BACK TO THE OPERATIONAL SCREENS THEN RELEASE THE RETURN KEY.

### To change a Profile

If there is a need to make an adjustment to a setting inside one segment of a profile, here are the instructions. A video demonstrating this procedure is available at [www.dairytechinc.com/support](http://www.dairytechinc.com/support).

From the operational mode when the machine is first turned on hold the RETURN button and with another finger, press the UP ARROW one

time to main menu. Release the RETURN button then use the DOWN ARROW to scroll to 'profile setup'. Press the RETURN button and enter the unlock code which is 10 by scrolling with the UP ARROW, the RETURN. Scroll down to Edit a Profile Segment, then RETURN, then select the profile to edit and press RETURN again. Now you will see the list of segments that make up the profile. For a 'colostrum normal' profile it will look like this:

1. Step
2. Ramp Rate
3. Dwell
4. Ramp Time
5. End

Select a segment by highlighting it then RETURN. Here is a list of how the settings should appear in each of those segments (Other profiles will have different segments and different settings depending on their purpose) This example shows the settings for

#### COLOSTRUM NORMAL

##### 1. Step:

Segment type	step
Target setpoint	139.0 F

(press RETURN to complete the segment update even if you did not change anything ... repeat the process for all segments)

##### 2. Ramp Rate:

Segment type	ramp rate
Target setpoint	139.5 F (this value would be 59.7 C)
Segment ramp rate	60.000 F
Auto Hold Type	Below Setpoint
Auto Hold Band Val	1.0 F
Event 1	Active
Event 2	Inactive
Event 3	Active

# Dairy Tech, Inc.

## *Service Manual: MilkWorks<sup>®</sup> Models*

<p>Event 4                    Inactive</p> <p>Event 5                    Inactive (press RETURN to complete)</p> <p>3. Dwell:</p> <p>Segment type            Dwell</p> <p>Dwell at 139.5 for      01:00:00</p> <p>Auto hold type          Below setpoint</p> <p>Auto hold band value 0.5 F</p> <p>Event 1                    Active</p> <p>Event 2                    Inactive</p> <p>Event 3                    Active</p> <p>Event 4                    Inactive</p> <p>Event 5                    Inactive (press RETURN to complete)</p> <p>4. Ramp Time</p> <p>Segment type            ramp time</p> <p>Target setpoint        90.0 F this is the cool point</p>	<p>Segment ramp time    00:00:02</p> <p>Auto hold type        above setpoint</p> <p>Auto hold band value 2.0 F</p> <p>Event 1                    Active</p> <p>Event 2                    Active</p> <p>Event 3                    Inactive</p> <p>Event 4                    Inactive</p> <p>Event 5                    Inactive (press RETURN to complete)</p> <p>5. END</p> <p>Segment type            End</p> <p>Segment end type      Control Off</p> <p>Event 1                    Inactive</p> <p>Event 2                    Inactive</p> <p>Event 3                    Inactive</p> <p>Event 4                    Inactive</p> <p>Event 5                    Inactive (press RETURN to complete)</p>
-----------------------------------------------------------------------------------------------------------------------------------------------------------------------------------------------------------------------------------------------------------------------------------------------------------------------------------------------------------------------------------------------------------------------------------------------------------------------------------------------------------------------------------------------------------------------------------------------------------------------------------------------------------------------------------	----------------------------------------------------------------------------------------------------------------------------------------------------------------------------------------------------------------------------------------------------------------------------------------------------------------------------------------------------------------------------------------------------------------------------------------------------------------------------------------------------------------------------------------------------------------------------------------------------------------------------------------------------------------------------------------------------------------------

**Accessing controller function**  
**\*\*\* IMPORTANT WARNING\*\*\***

**DO NOT ALTER SETTINGS IN THE CONTROLLER WITHOUT CONSULTING A DAIRY TECH REPRESENTATIVE .... ANY UNAUTHORIZED ADJUSTMENTS WILL VOID THE PRODUCT WARRANTY AND MAY LEAD TO SERIOUS HEALTH CONSEQUENCES FOR THE CALVES.**

To access the controller main menu for milk/heater temperature settings as well as process timing, follow these steps:

## Accessories:

### Perfect Udder® Colostrum Management Kits

Permit storage, freezing, pasteurization, reheating and feeding directly from the bag  
Avoid the pitfalls of bottles and ensure calf health with disposable colostrum feeding.







# Wiring Schematic for MilkWorks Gold with 400VAC 3 Phase Supply

REV.	DESCRIPTION	DATE	BY
A	Initial Release	2/5/2013	KWH

## MilkWorks - Gold - 3 Phase - Schematic w/DC Level Detection 400VAC, 3P, 30A Breaker

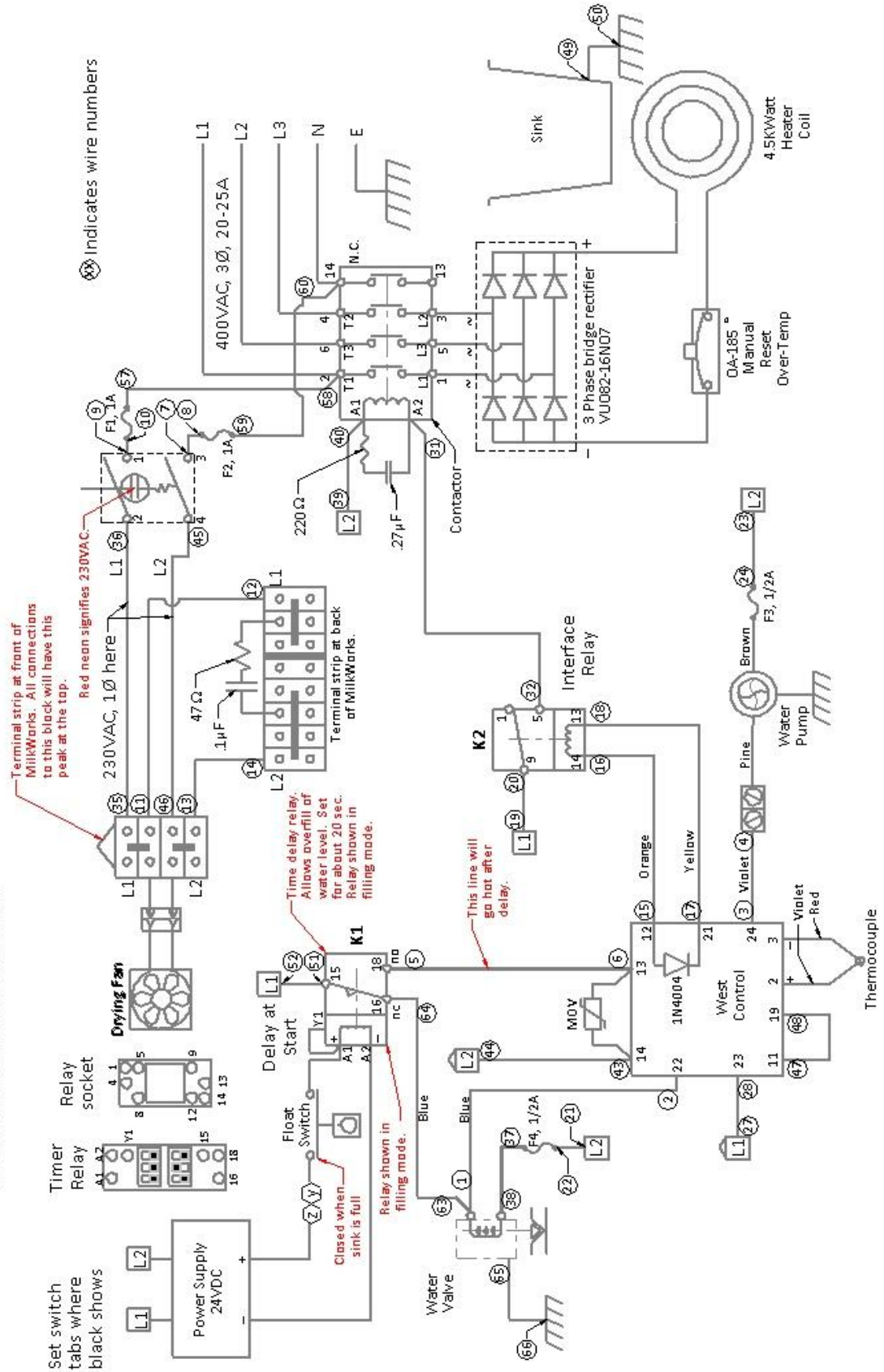

# Wiring Schematic for MilkWorks Gold with AC Voltage Used in Water Level Sensing Circuit.

REV.	DESCRIPTION	DATE	BY
A	Initial Release		

## MilkWorks - Gold - 230VAC - Schematic

5/25/2012

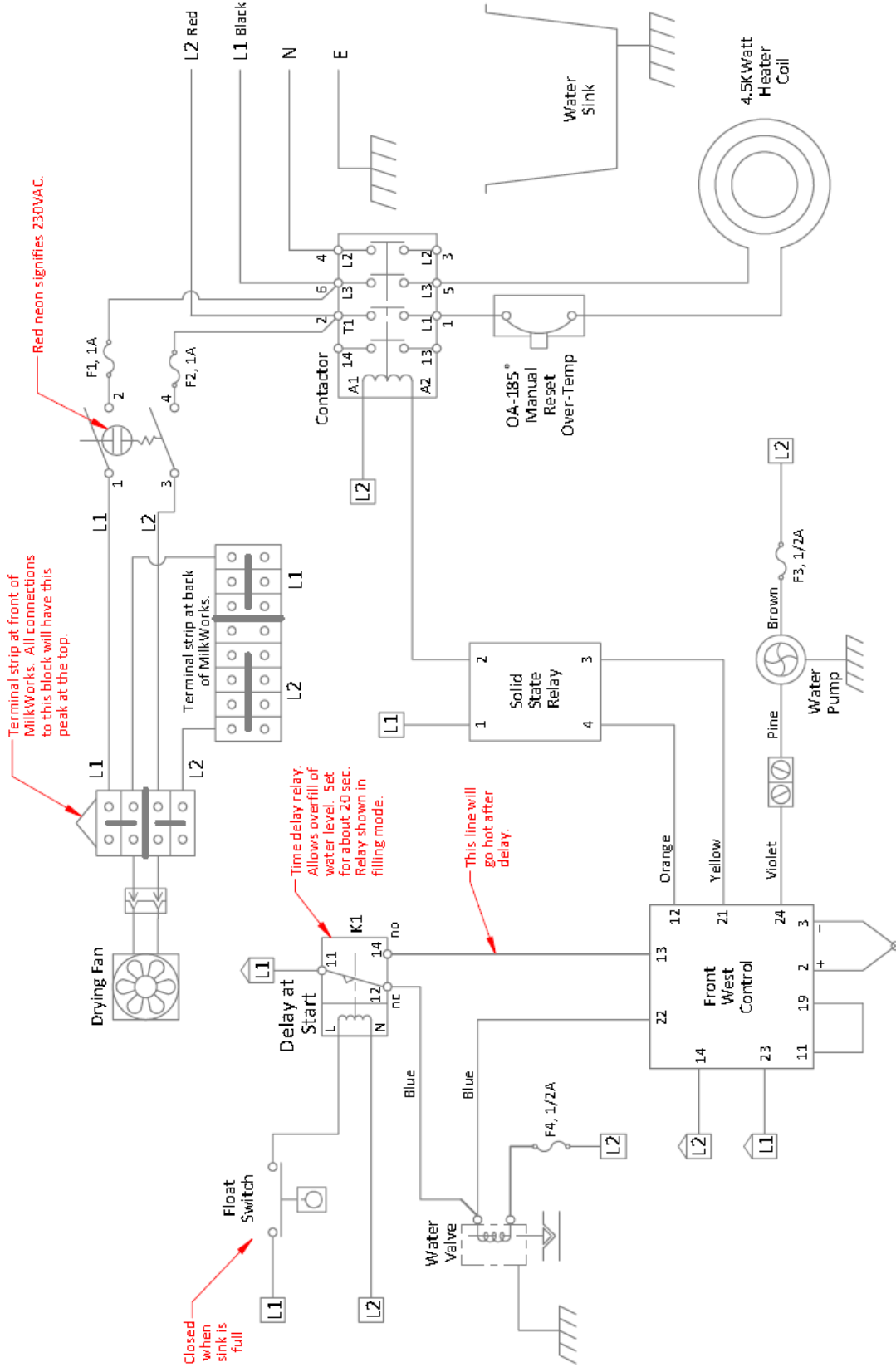

# Wiring Schematic for MilkWorks Silver w/Switch Setting Delay Relay and 24Volt DC Power Supply.

## MilkWorks - Silver - 230VAC - Schematic w/Switch Setting Delay Relay & 24VDC Supply

10/29/2012

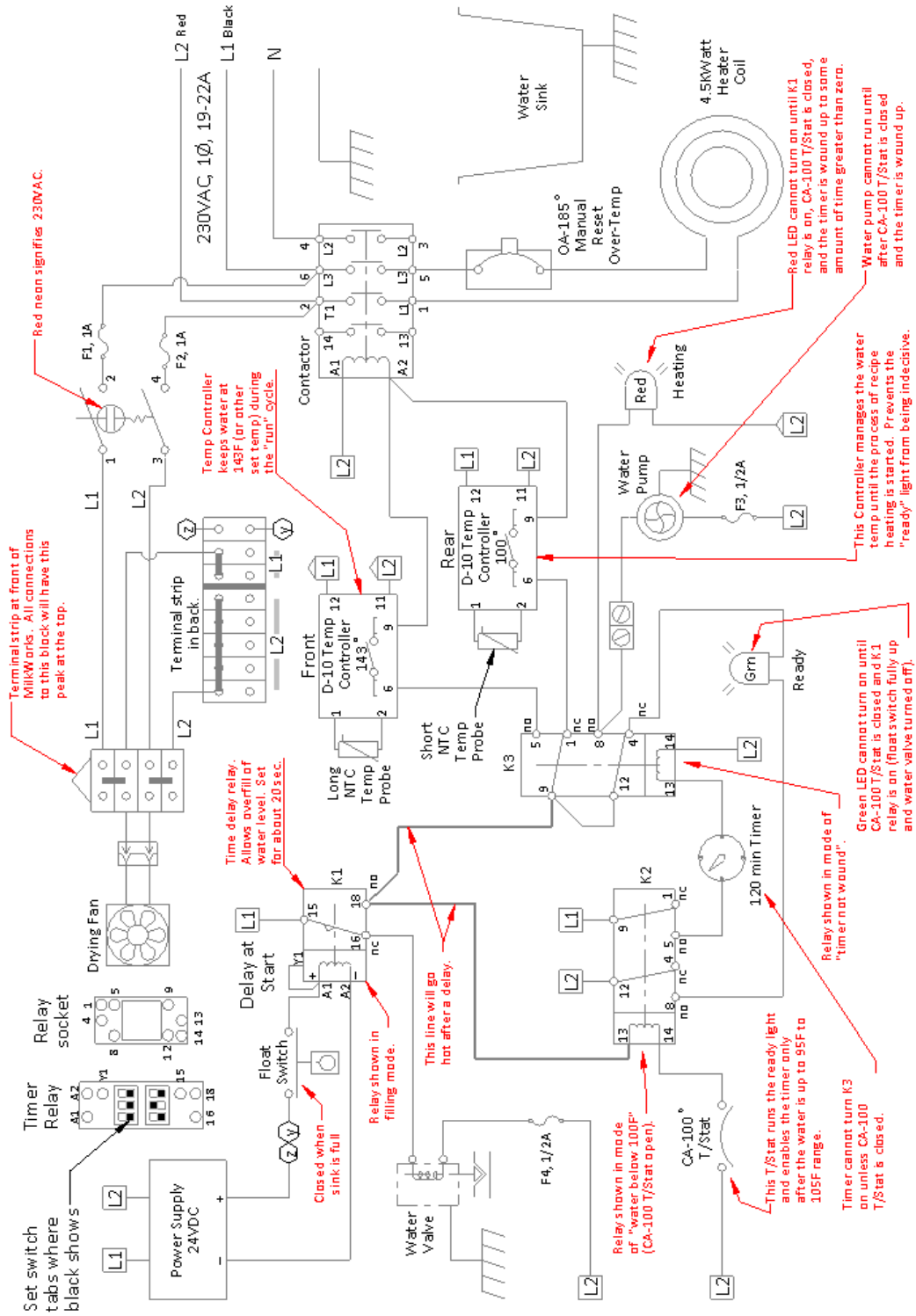



# Wiring Schematic for MilkWorks Silver w/ Knob Adjustable Delay Relay and No Special Power Supply.

REV.	DESCRIPTION	DATE	BY
A	Initial Release		

## MilkWorks - Silver - 230VAC - Schematic

5/25/2012

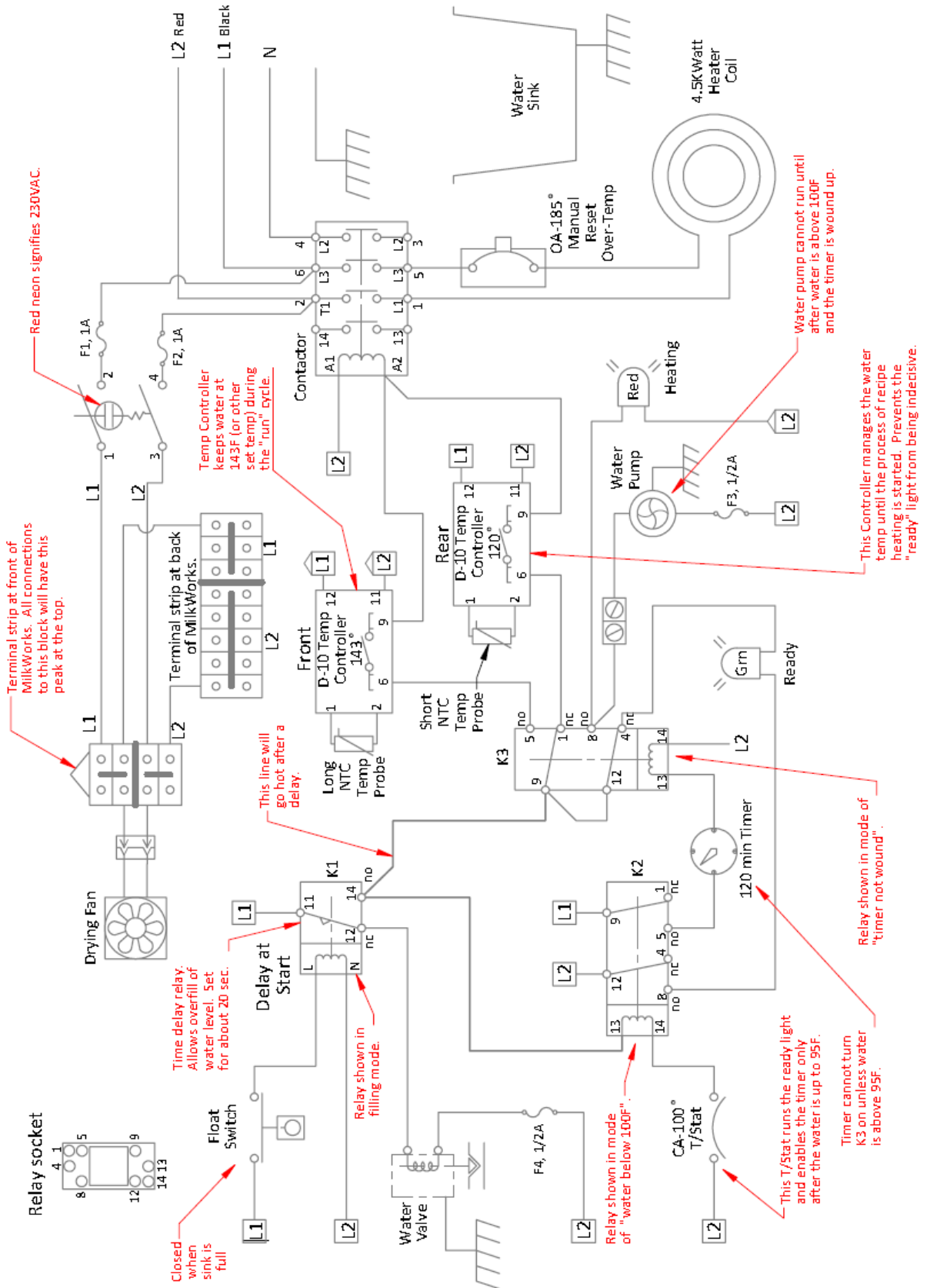



## Replacement Parts List

### Contact Dairy Tech, Inc.

Dairy Tech, Inc.  
PO Box 250, Severance, CO 80546  
34824 CR 29, Greeley, CO 80631

**Phone:**

1-866-384-2697

1-970-674-1888

1-970-686-5871 fax

Monday – Friday

7:00 a.m. – 6:00 p.m., MST

**Web:**

[www.dairytechinc.com](http://www.dairytechinc.com)

[www.perfectudder.com](http://www.perfectudder.com)

[www.milk-works.com](http://www.milk-works.com)

MilkWorks Leg Kit Assembly Instructions



# MilkWorks Leg Kit Assembly Instructions.

Step 1 should be done on a flat surface.

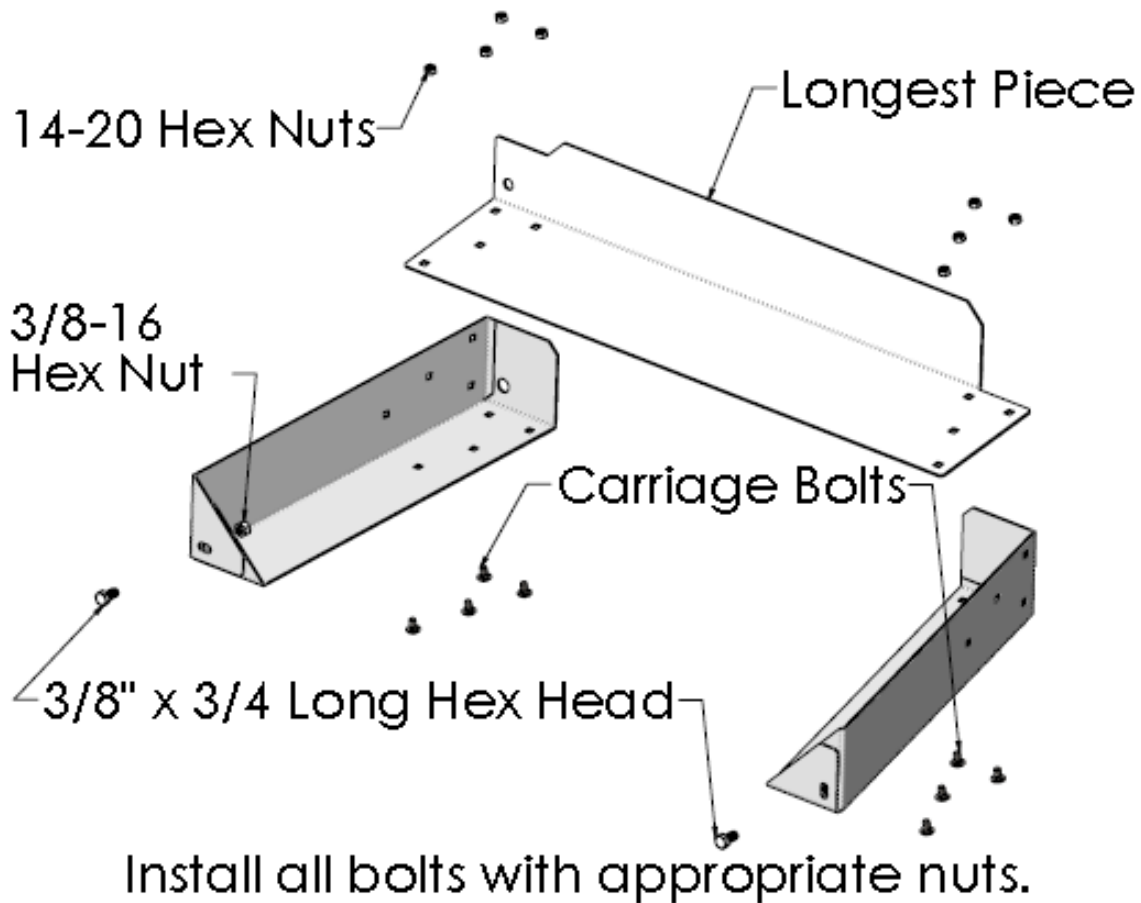

Make two assemblies like this.  
Finger tighten for now.

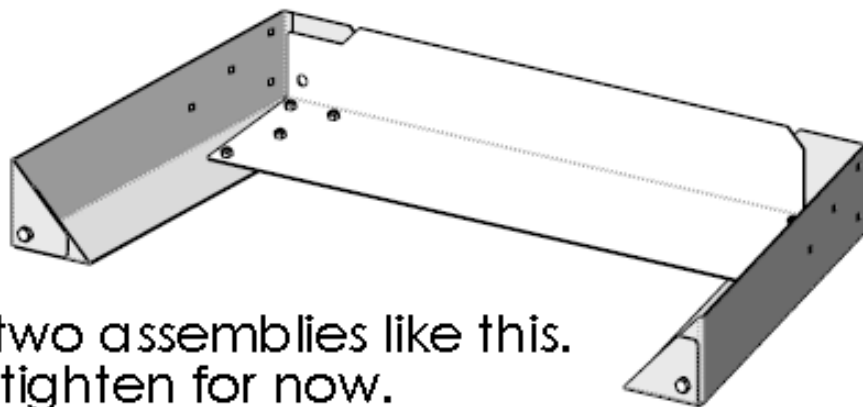

Step 2 should be done on a flat surface.

Install remaining sides

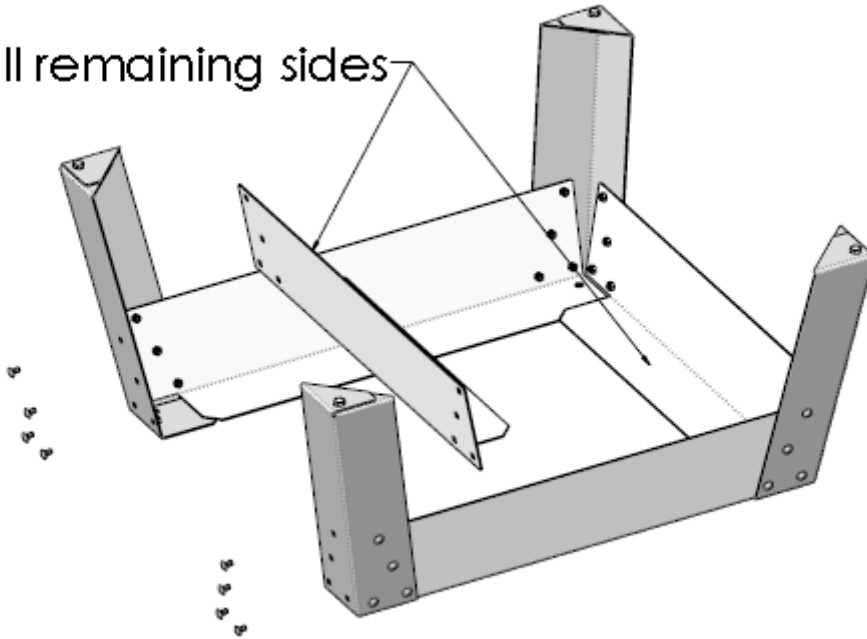

Install all bolts with appropriate nuts.  
Finger tighten all nuts at this time.

Step 3 will be done with the legs standing.

Place the leg set on a flat surface and apply only enough force to the top of the legs so they find their largest footprint. Check that the top surface is as level as the floor surface, then tighten all hardware.

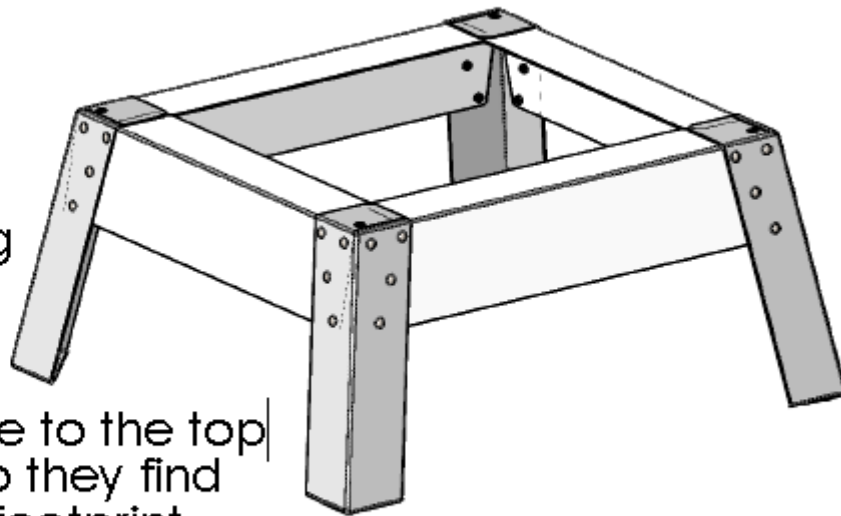

Step 4 requires access to the bottom of MilkWorks.

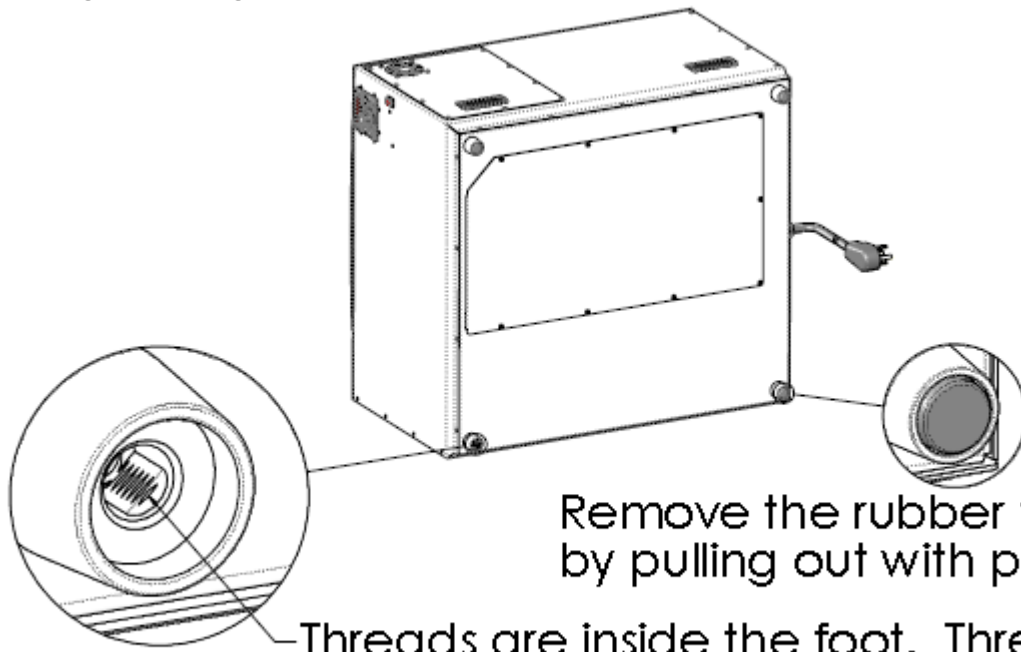

Remove the rubber feet by pulling out with pliers.

Threads are inside the foot. Threads are partial at first. Use care to avoid cross threading during bolt entry.

In all four corners, install washers and  $3/8 \times 1 \frac{1}{2}$  hex bolts into the underside of the feet to secure the MilkWorks to the legs.

